

HEATSTRIP®



OPERATION, INSTALLATION AND MAINTENANCE MANUAL

Outdoor Radiant Gas Heater

X-DGR32PLP-HEAD &
X-DGR32PLP-STAND

DANGER

If you smell gas:

1. Shut off gas to the appliance.
2. Extinguish any open flame.
3. If odor continues, keep away from the appliance and immediately call your gas supplier or your fire department.

DANGER

1. Do not store or use gasoline or other flammable vapors and liquids in the vicinity of this or any other appliance.
2. An LP-cylinder not connected for use shall not be stored in the vicinity of this or any other appliance.

WARNING

*FOR OUTDOOR USE ONLY.
Appliance is to be protected from rain.*

WARNING

Improper installation, adjustment, alteration, service, or maintenance can cause property damage, injury or death. Read this operating and assembly instruction thoroughly before installing or serving this heater.

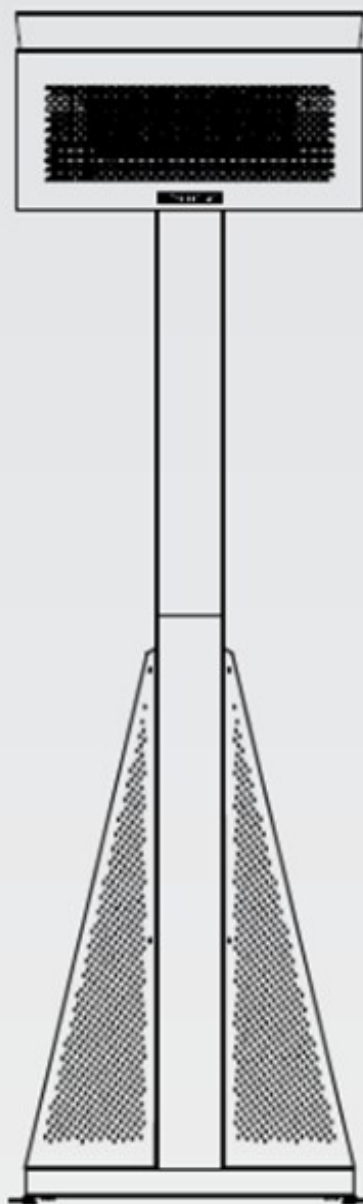

Table of Contents

Pre-Assembly Instructions.....	3
Primary Safety Warnings.....	4-5
Product Overview.....	6
Part Diagrams and Lists.....	8-10
Assembly Instructions.....	11-13
Use and Care Instruction.....	14-15
Lighting Instruction.....	16
Troubleshooting.....	17
Cleaning and Maintenance.....	17
Warranty Terms.....	Back Cover

Contact AMD Direct for warranty or replacement parts

Phone: [800.966.8126](tel:800.966.8126)

Important: Use only Heatstrip replacement parts. The use of any part that is not Heatstrip replacement part can be dangerous and will also void your product warranty. Keep this Operator's Manual for convenient referral and for part replacement.

To obtain the correct replacement parts for your Heater please refer to the part numbers in this parts list. The following information is required to ensure you receive the correct parts:

1. Model and Serial Number (see CSA label on Heater)
2. Part Number
3. Part Description
4. Quantity of parts needed

PRE-ASSEMBLY

Read and perform the following pre-assembly instructions:

Required Tools

- Protective work gloves
- Protective eyewear
- Phillips Head Screwdriver

- You will need assistance from another person to handle the heater and other large, heavy parts.
- Open lid of shipping carton and remove parts box and packing materials. Lay cardboard sheet on floor to use as a work surface to protect floor and heater parts from scratches.
- You may slice the carton front corners with a utility knife to lay open the carton front panel. This allows you to raise the heater and remove the components packed inside, making it easier to lift. Use the lid of carton front as work surface to protect floor and heater parts from scratches.
- Use the Part Diagrams to ensure all items are included and free of damage.
- Do not assemble or operate the heater if it appears damaged. If there are damaged or missing parts when you unpack the shipping cartons or you have questions during assembly process, call AMD Direct [800.966.8126](tel:800.966.8126)
- Any guard or protective device removed from servicing the heater must be replaced prior to operating the heater.
- **Note:** You should inspect the heater and connections before each use. You should perform periodic leak tests on propane hose. The *Cleaning and Maintenance* section of this manual has detailed information needed. The heater should be inspected/ serviced at least annually by a qualified service person.

Heater Installation Codes

The installation must conform with local codes or, in their absence of local codes, with either:

- **National Fuel Gas Code**, ANSI Z223.1/NFPA54
- **Natural Gas And Propane Installation Code**, CSA B149.1
- **Propane Storage And Handling Code**, B149.2

For Liquid Propane (LPG)

The gas manifold supply pressure must be regulated at 11" water column utilizing a Thermofilm authorized regulator.

The minimum inlet pressure to the regulator from the tank is 10 psi and maximum pressure is 150 psi.

LPG CYLINDER USE AND SAFETY

- LP Gas heater models are designed for use with a standard 20 lb. Liquid Propane Gas (LP Gas) tank, not included with heater. Never connect your gas heater to an LP Gas tank that exceeds this capacity. A tank of approximately 12 inches in diameter by 18-1/2 inches high is the maximum size LP Gas tank to use. You must use an "OPD" gas tank which offers a listed Overfill Prevention Device. This safety feature prevents the tank from being overfilled which can cause a malfunction of the LP Gas tank, regulator and/or heater.
 - The LP Gas tank must be constructed and marked in accordance with the Specifications for LP-gas cylinders of the U.S. Department of Transportation (DOT); or the Standard for Cylinders, Spheres and Tubes for Transportation of Dangerous Goods and Commission, CSA B339, as applicable.
 - The LP Gas tank must have a shutoff valve, terminating in an LP Gas supply tank valve outlet, that is compatible with a Type 1 tank connection device. The LP Gas tank must also have a safety relief device that has a direct connection with the vapor space of the tank.
 - The tank supply system must be arranged for vapor Withdrawal
 - The LP Gas tank must have a collar to protect the tank valve. If the collar is damaged in any way, the tank must be replaced prior to using the heater.
 - Never connect an unregulated LP gas tank to your gas heater. The gas regulator assembly supplied with your gas heater is adjusted to have an outlet pressure of 11" water column (W.C.) for connection to an LP gas tank. Only use the regulator and hose assembly supplied with your gas heater.
- Replacement regulators and hose assemblies must be those specified by the Manufacturer.
- Have your LP Gas dealer check the release valve after every filling to ensure it remains free of defects.
- Always keep LP Gas tank in upright position.
- Do not subject the LP Gas tank to excessive heat.
- If you store your gas heater in the garage always disconnect the LP Gas tank first and store it safely outside.
- Never store an LP Gas tank indoors. LP Gas tanks must be stored outdoors in a well-ventilated area and out of the reach of children.
- Do not store a spare LP-gas cylinder under or near this appliance; Never fill the cylinder beyond 80 percent full

OUTDOOR AREAS SAFETY APPLIANCE LOCATIONS

This appliance is for outdoor use only.

This appliance must be placed on level firm ground.

This appliance shall only be used in an above ground open-air situation with natural ventilation, without stagnant areas, where gas leakage and products of combustion are rapidly dispersed by wind and natural convection.

Any enclosure in which the appliance is used shall comply with one of the following:

1. An enclosure with walls on all sides, but at least one permanent opening at ground level.
2. Within a partial enclosure that includes an overhead cover and no more than two walls.
3. Within a partial enclosure that includes an overhead cover and more than two walls, the following shall apply:
 - At least 25% of the total wall area is completely open.
 - At least 30% of the remaining wall area is open and unrestricted.
 - In the case of balconies, at least 20% of the total wall area shall be and remain open and unrestricted.

*The following diagrams are examples of outdoor areas.
These same principles apply to any other shaped area.*

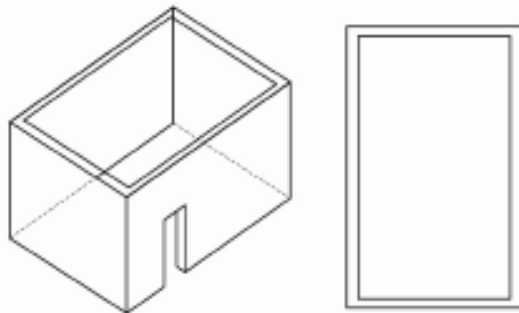

FIGURE E1—OUTDOOR AREA—EXAMPLE 1

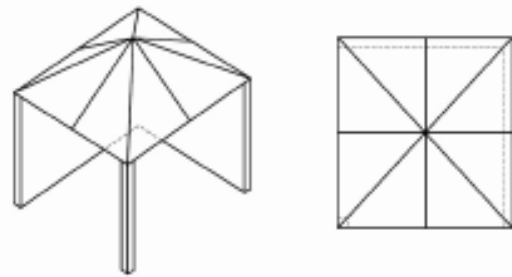

FIGURE E2—OUTDOOR AREA—EXAMPLE 2

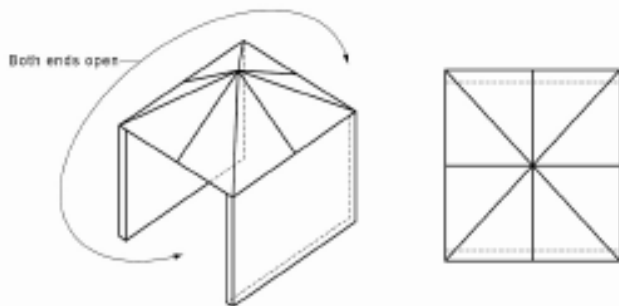

FIGURE E3—OUTDOOR AREA—EXAMPLE 3

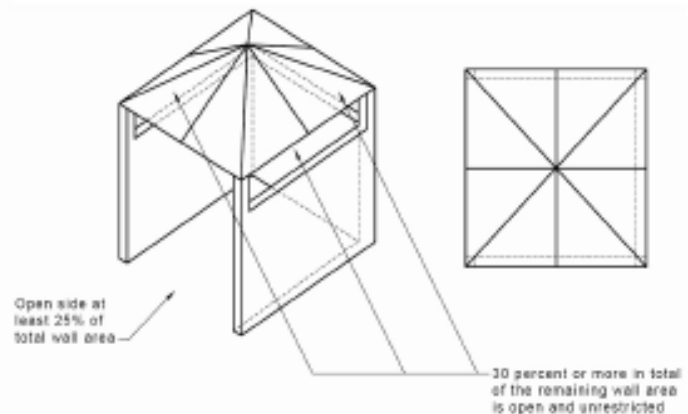

FIGURE E4—OUTDOOR AREA—EXAMPLE 4

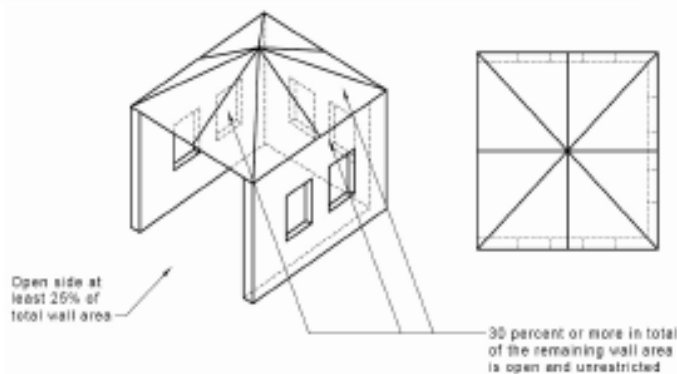

FIGURE E5—OUTDOOR AREA—EXAMPLE 5

FOR YOUR SAFETY



WARNING



1. Do NOT store or use gasoline or other flammable liquids and vapors within 25 feet (8m) of this appliance.
2. Do NOT use this outdoor heater near automobiles, trucks, vans or recreational vehicles.
3. Do NOT use this outdoor heater under any overhead or near any unprotected combustible materials. Avoid using near or under overhanging trees and shrubs.
4. Always use this outdoor heater on a hard, level, non-combustible surface such a concrete, rock or stone.
5. Children and adults should be alerted to the hazards of high surface temperatures and should stay away to avoid burns or clothing ignition.
6. Young children should be carefully supervised when they are in the area of the heater.



WARNING



- Failure to comply with these instructions could result in a fire or explosion that could cause serious bodily injury, death or property damage.
- Before using this gas appliance read all instructions and perform all gas leak-check procedures even if the product was pre-assembled by the retailer or manufacturer.



WARNING



Hot while in operation. Do not touch.
Keep children, clothing, furniture, gasoline and other liquids having flammable vapors away.



WARNING



- LPG heater models must be used with Liquid Propane Gas and the regulator assembly supplied.
- Natural Gas models must be used with Natural Gas only. Any attempt to convert the heater from one fuel type to another is extremely hazardous and will void the warranty.
- Never disconnect the gas regulator or any gas fitting while your heater is lit. A lit heater can ignite leaking gas and cause a fire or explosion which could result in property damage, personal injury or death.
- Keep gas regulator hose away from hot heater surfaces and dripping grease. Avoid unnecessary twisting of hose. Visually inspect hose prior to each use for cuts, cracks, excessive wear or other damage. If the hose appears damaged do not use the gas heater. Call Thermofilm for an authorized replacement hose.



WARNING



- Use your heater at least 3 feet away from any wall or surface. Use your heater at least 3 feet away from combustible objects that can melt or catch fire (such as vinyl or wood siding, fences and overhangs) or sources of ignition including pilot lights on water heaters and live electrical appliances.
- Never use your gas heater in a garage, porch, shed, breezeway or any other enclosed area.
- Never obstruct the flow of ventilation air around your gas heater housing.

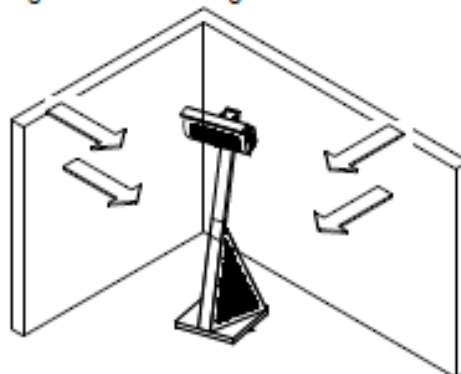

Product Overview

Specification

Outdoor Radiant Gas Heater

Model Type	Post
Model Number	X-DGR32PLP-HEAD & X-DGR32PLP-STAND
Gas Type	Propane
Test Point Pressure	2.74 KPA
Nominal Gas Consumption	32,225 BTU/HR
Injector Size	0.84 mm *4
Gas Cylinder Connection	QCC1
Hose Connection	5/8" - 18 UNF (3/8"SAE)
Net Weight	31.5 kg

Installation Clearances

This appliance must only be used in a well ventilated area. The following clearance should be followed:

The heater should not be installed:

- Where heat ignition can cause damage to gas cylinders/lines.
- Near other combustible materials.
- In open locations subject to rain.

Heater should be installed to allow adequate:

- Clearance around air openings to combustion chamber.
- Clearance from combustible material.
- Provisions for accessibility and clearance for combustion and ventilating air supply.

Dimension and Clearance Detail

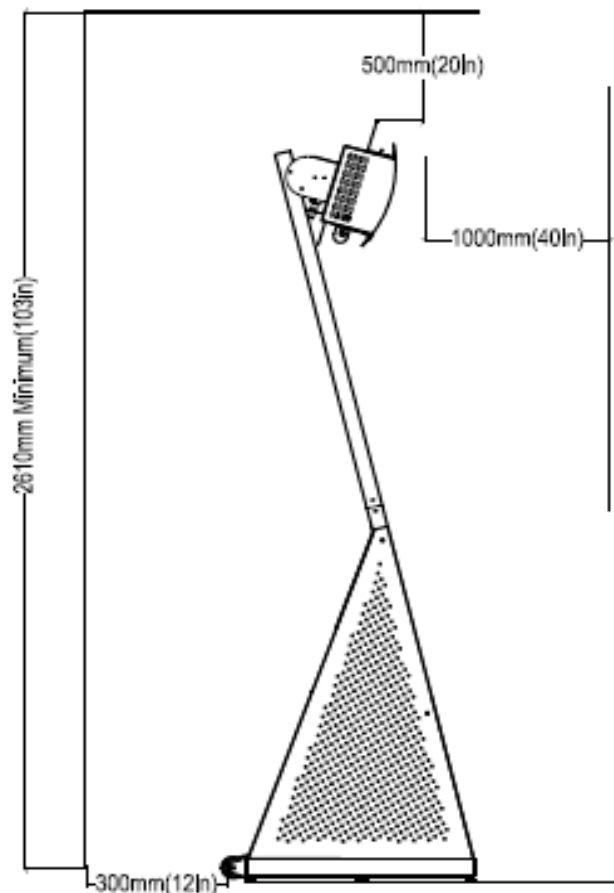
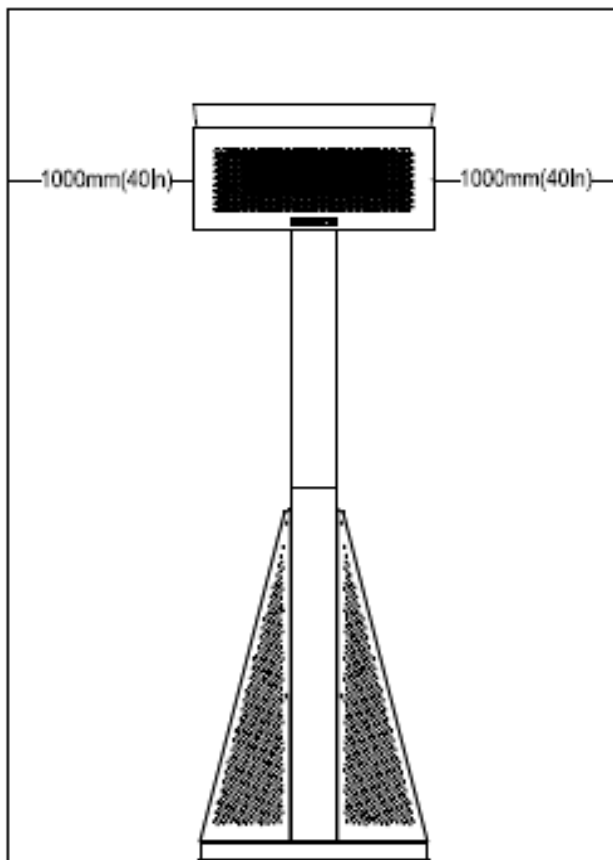

IMPORTANT 1 : MINIMUM CLEARANCES TO COMBUSTIBLE MATERIAL, FROM TOP 500 mm(20 inches),
SIDE 1000 mm(40 inches), FRONT 1000 mm(40 inches), REAR 300 mm(12 inches).

IMPORTANT 2 : ALWAYS LOCATE AND OPERATE HEATER ON A FLAT-LEVEL SURFACE.

Hardware Pack For TGH34PLUL-2

PART #	PART DESCRIPTION	QTY	PURPOSE OF PART
P06033002A	Hardware Pack	1	For use in assembly of TGH34PL-2
S112M06102	Pan Head Screw M6 x 10mm	5	Install Lower Post to Base
S112M06102	Pan Head Screw M6 x 10mm	4	Install Side Panels to Lower Post & Base
S112M06102	Pan Head Screw M6 x 10mm	6	
S112M05102	Pan Head Screw M5 x 10mm	3	Install Head Deflector to Head
S112M06102	Pan Head Screw M6 x 10mm	14	Install Back Panel to Upper Post
P05501166D	Pin $\Phi 6$ x 150mm	1	Install Heater to Upper Post
P05501164B	R Cotter Pin	1	
S020100223	Bolt M6 x 150mm	1	
S411M0606A	Wing Nut M6	1	
S112M06102	Pan Head Screw M6 x 10mm	6	Install Upper Post to Lower Post
S112M06102	Pan Head Screw M6 x 10mm	2	Install Real panel to Side Panel & Lower Post
S112M05102	Pan Head Screw M5 x 10mm	4	
	Screwdriver	1	

Hardware Diagram for TGH34PLUL-2



Pan Head Screw M6x10mm
Qty. 29
Part # S112M06102



Pan Head Screw M5x10mm
Qty. 7
Part # S112M05102



Pan Head Screw M6x10mm
(Pre-assembly in post upper)
Qty. 8
Part # S112M06102



Pin $\Phi 6$ x 150mm
Qty. 1
Part # P05501166D



R Cotter Pin
Qty. 1
Part # P05501164B



Bolt M6 x 150mm
Qty. 1
Part # S020100223



Wing Nut M6
Qty. 1
Part # S411M0606A



AA Battery

Parts Diagram

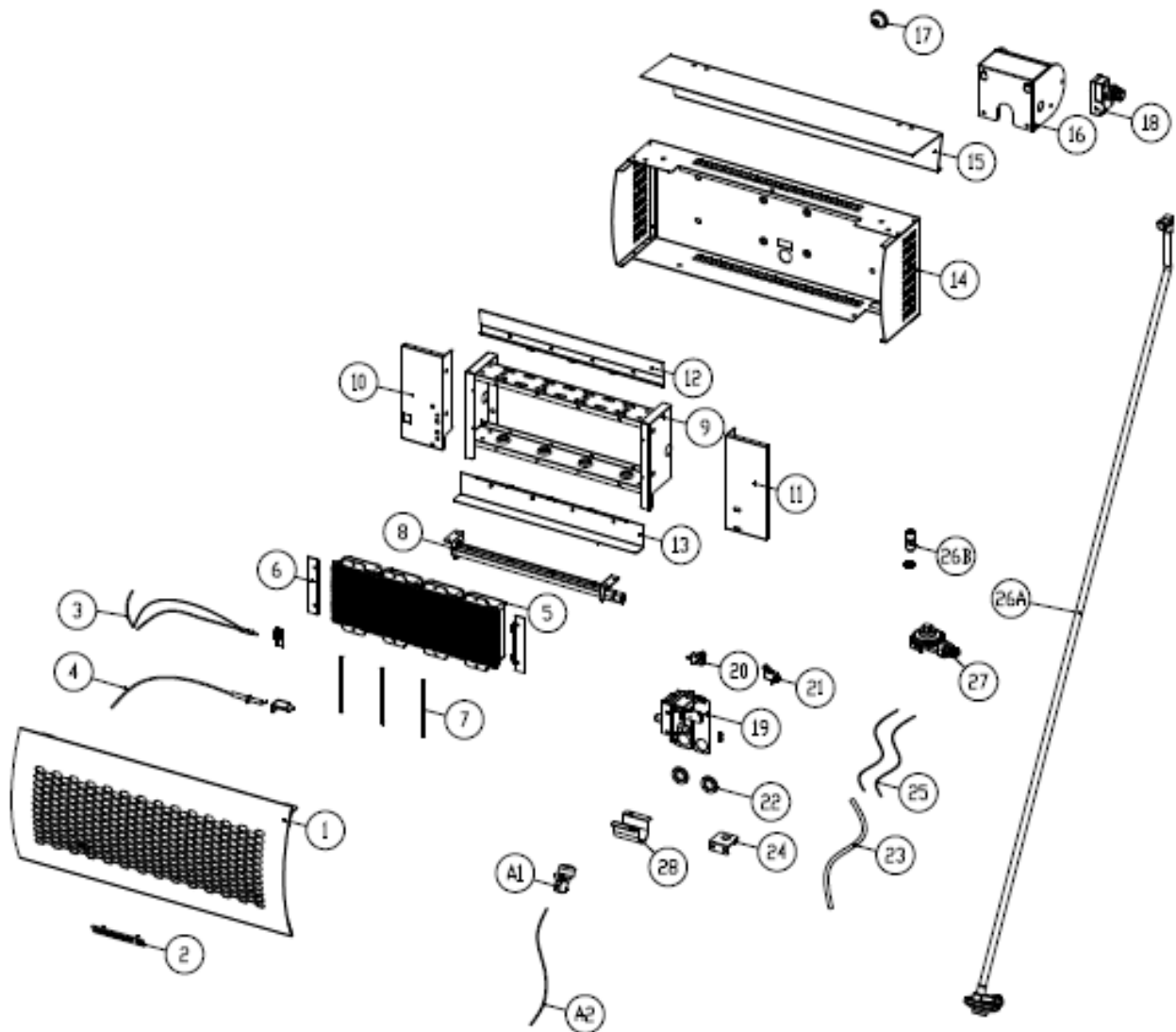

Contact AMD Direct for warranty or replacement parts

Phone: [800.966.8126](tel:800.966.8126)

Important: Use only Heatstrip replacement parts. The use of any part that is not Heatstrip replacement part can be dangerous and will also void your product warranty. Keep this Operator's Manual for convenient referral and for part replacement.

To obtain the correct replacement parts for your Heater please refer to the part numbers in this parts list. The following information is required to ensure you receive the correct parts:

1. Model and Serial Number (see CSA label on Heater)
2. Part Number
3. Part Description
4. Quantity of parts needed

Parts List

KEY	DESCRIPTION	PART NO.	QTY.
1	Protective Guard	P03351045D	1
2	Name Plate	P00408001A	1
3	Thermocouple with wire	P05308007B	1
4	Electrode with wire	P02618082A	1
5	Burner Assembly	P02005035D	4
6	Burner Bracket, Side	P033510324	2
7	Burner Holder	P020110804	3
8	Manifold assembly - NG	Y0060898	1
	Orifice (NG)	P06536043A	4
9	Burner Assembly Frame	P03351029D	1
10	Bowl Bracket, Left	P033510464	1
11	Bowl Bracket, Right	P033510474	1
12	Burner Bracket, Upper	P033510484	1
13	Burner Bracket, Lower	P033510494	1
14	Head Bowl	P03351050D	1
15	Heat Deflector	P03351034D	1
16	Head Assembly Bracket	P03351051D	1
17	Protective Ring	P05556002I	1
18	Electric Ignitor	P02505032F	1
19	Gas valve Assembly	Y0060887	1
	Gas valve	P03253002F	1
	Spring	P05504116E	1
20	Micro Switch (ON)	P05382007D	1
21	Micro Switch (OFF)	P05382008D	1
22	Finger Protective Ring	P055560033	2
23	Connecting Hose	P03720006F	1
24	Hose Bracket	P03328091D	1
25	Electrode wire set	P02616080L	2
26	Connector with Nut	P03907013A	1
28	Thermocouple Valve Cover	P069090104	1
A1	Tilt switch	P05380005A	1
A2	Tilt switch wire	P02616081L	1

Parts Diagram

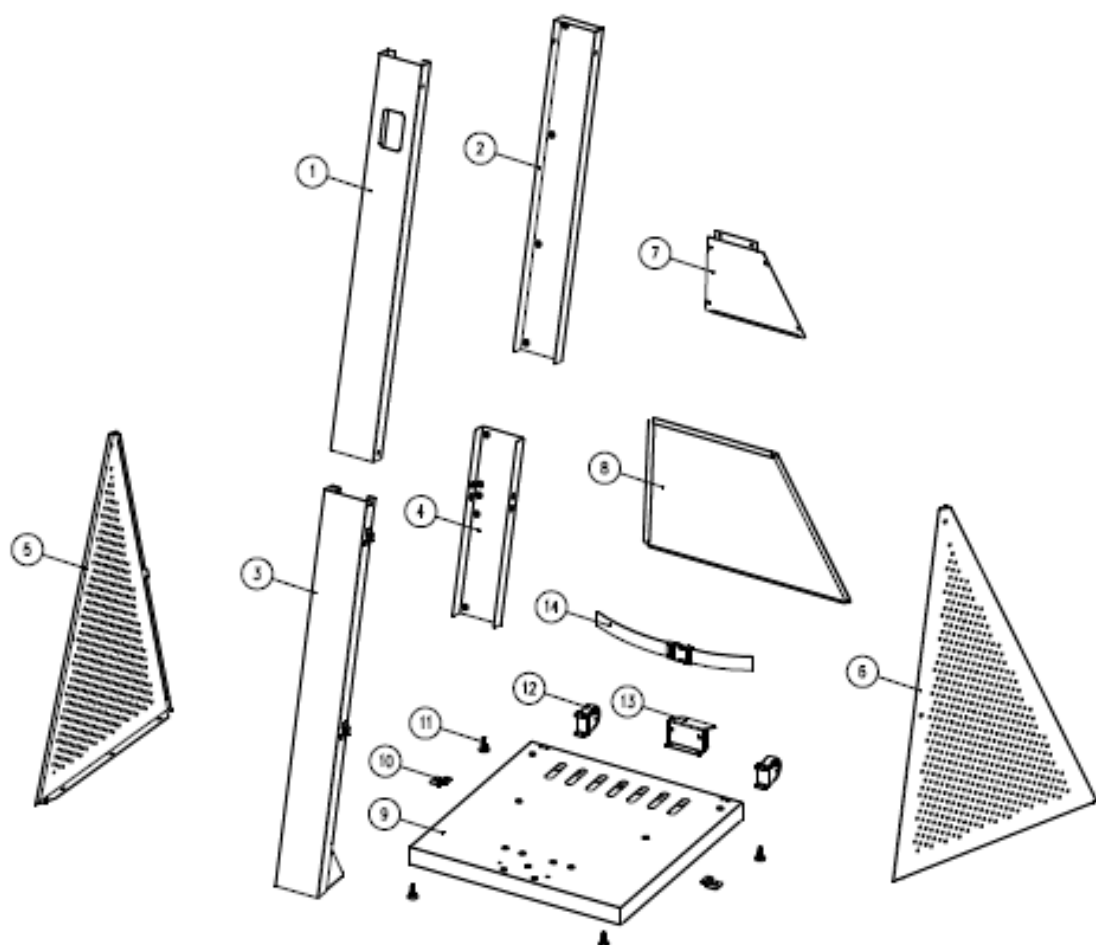

Parts List

KEY	DESCRIPTION	PART NO.	QTY.
1	Post - Front, Upper	P03351016D	1
2	Post - Rear, Upper	P03351006D	1
3	Post - Front, Lower	P03351015D	1
4	Post - Rear, Lower	P03351014D	1
5	Side Panel / Left	P03351017D	1
6	Side Panel / Right	P03351018D	1
7	Rear Panel / Upper	P03351019D	1
8	Rear Panel / Lower	P03351020D	1
9	Base(Heatstrip)	P03351001D	1
10	Base Bracket	P03351013D	2
11	Skid Pad	P05518114I	4
12	Wheel	P03351004D	2
13	Pedal	P03351002D	1
14	Gas Cylinder Strap	P04016001E	1

Assembly Instructions

CAUTION: To assemble this heater, you should obtain assistance from another person when handling the larger, heavier pieces.

1 Install the Lower Post

- attach 2 Pan Head Screw on Base halfway.
- attach Lower Post to Base using 3 Pan Head Screws M6x10mm, then tighten all the screws securely.



Pan Head Screw M6x10mm
Qty. 5
Part # S112M06102

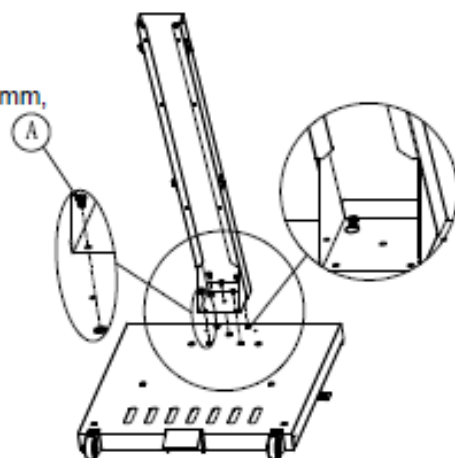

2 Install Side Panels

- Place two Side Panels onto the Base.
- Install the Left Side Panel to the Lower Post using 2 Pan Head Screws M6x10mm. Install the Left Side Panel to the Base using 3 Pan Head Screws M6x10mm.
- Repeat the same procedure for the Right Side Panel, then tighten all the screws securely.



Pan Head Screw M6x10mm
Qty. 10
Part # S112M06102

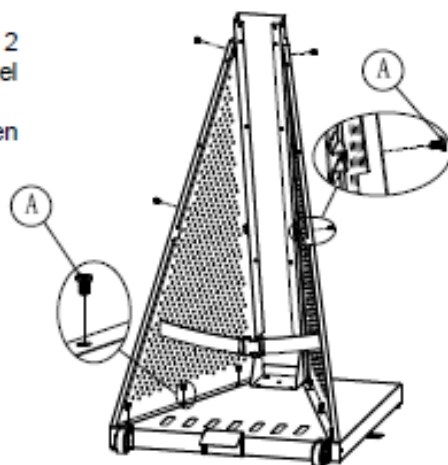

3 Install Head Deflector and Battery

- Install Head Deflector to the Head Assembly using 3 Pan Head Screws M5x10mm, then tighten all the screws securely.
- Attach AA Battery



Pan Head Screw M5x10mm
Qty. 3
Part # S112M05102



AA Battery

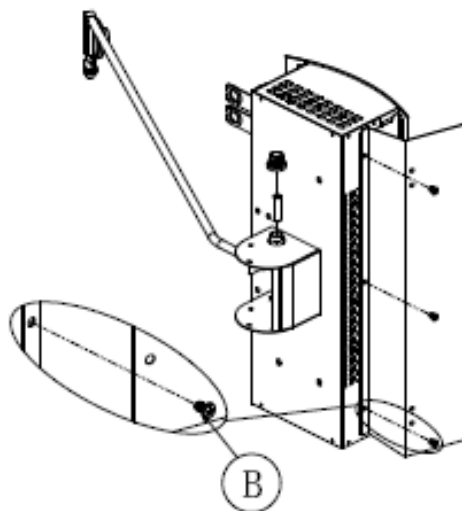

Assembly Instructions

4

- Lay Heater Upper Assembly on a non-abrasive surface (carton or table).
- Remove pre-assembly screw from back panel of post upper.
- Insert the Regulator with Hose to the Upper Post and attach Back Panel using 14 Pan Head Screws M6x10mm, then tighten all the screws securely.



Pan Head Screw M6x10mm
Qty. 14
Part # S112M06102

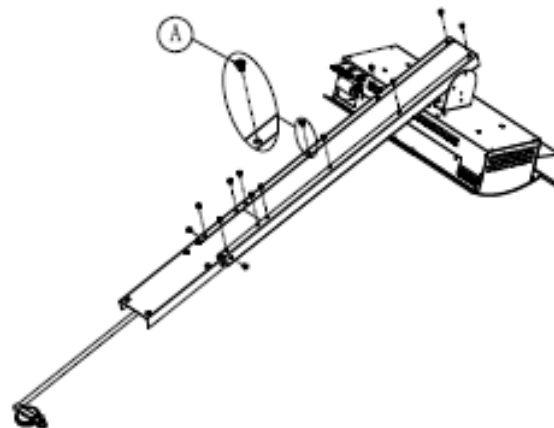
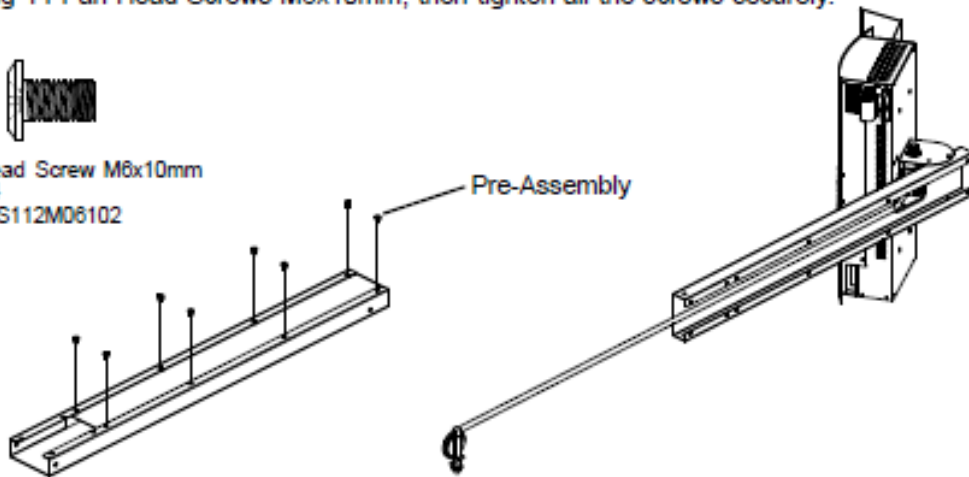

Pin $\Phi 8 \times 150\text{mm}$
Qty. 1
Part # P05501166D



R Cotter Pin
Qty. 1
Part # P05501164B

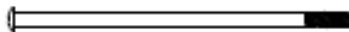

Bolt M6 x 150mm
Qty. 1
Part # S020100223



Wing Nut M6
Qty. 1
Part # S411M0606A

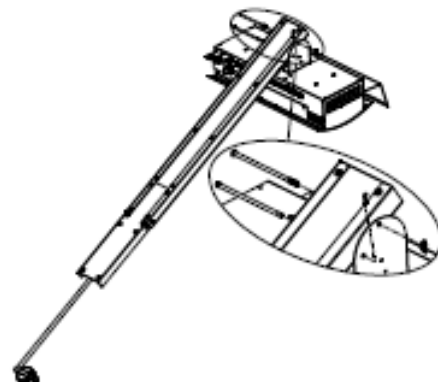

Assembly Instructions

5 Install Post Connector

- Insert the Upper Post with heater head and attach 6 Pan Head Screws M6x10mm, then tighten all the screws securely.



Pan Head Screw M6x10mm
Qty. 6
Part # S112M06102

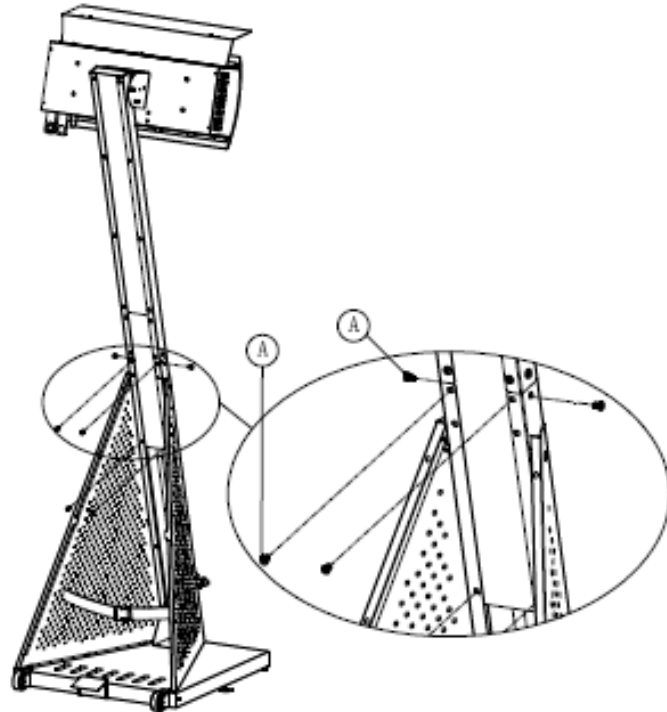

6 Install Rear Panels

- Install the Upper Rear Panel to the Lower Post using 2 Pan Head Screws M6x10mm.
Install the Upper Rear Panel to the Side Panels using 4 Pan Head Screws M5x10mm, then tighten all the screws securely.
- Place the Lower Rear Panel in position over the gas bottle enclosure area.



Pan Head Screw M6x10mm
Qty. 2
Part # S112M06102



Pan Head Screw M5x10mm
Qty. 4
Part # S112M05102

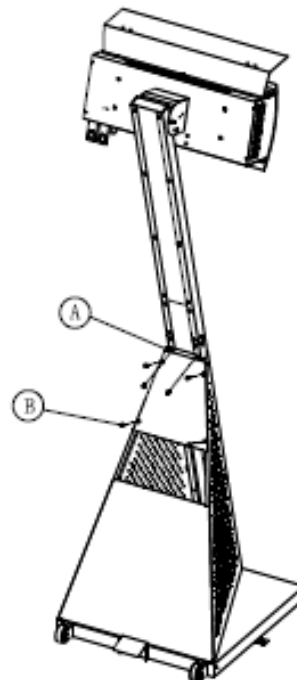

USE AND CARE INSTRUCTIONS

Check for Gas Leaks

Never test for leaks with an open flame. Prior to first use, at the beginning of each season, or every time your LP Gas Cylinder is changed, you must check for gas leaks. Follow these three steps:

1. Make a soap solution by mixing one part liquid detergent and four parts water.

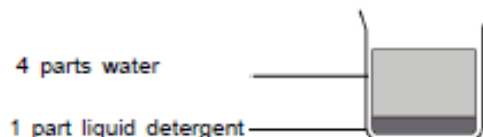

2. Pull Trigger "OFF" down, then turn on gas at source.

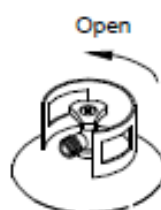

3. Apply the soap solution to all visible gas connections. If bubbles appear in the soap solution the connections are not properly sealed. Check each fitting and tighten or repair as necessary.

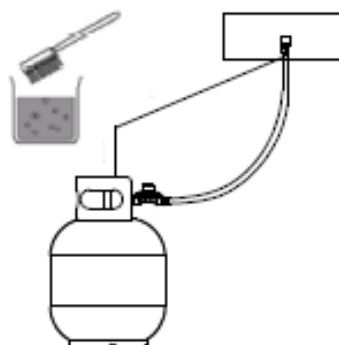

Failure to read and follow the Use and Care Instructions could result in a fire or explosion that could cause serious bodily injury, death or property damage.



If you have a gas leak that cannot be repaired by tightening. Turn off the gas at the source, disconnect fuel line from your heater and call your gas supplier or a plumber for assistance.

LP Gas Model only:

Connect Regulator with Hose to your LP Gas Tank

- Turn Burner Valve to the OFF position.
- Inspect the valve connection port and regulator assembly for damage or debris. Remove any debris. Never use damaged or plugged equipment.
- Connect the regulator assembly to the tank valve and **HAND TIGHTEN** nut clockwise to a full stop. **DO NOT** use a wrench to tighten because it could damage the Quick Coupling Nut and result in a gas leak/fire hazard.
- Open the tank valve 1/4 to 1/2 (counterclockwise) and use a soapy water solution to check all connections for leaks before attempting to light your heater. See "Check all Connections for LP Gas Leaks". If a leak is found, turn the tank valve off and do not use your heater until the leak is repaired.

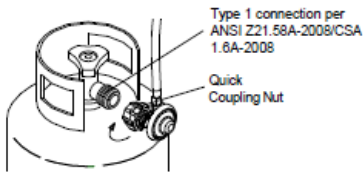

CAUTION:

When the heater is not in use the gas must be turned off at the tank. Place dust cap on cylinder valve outlet whenever the cylinder is not in use. Only install the type of dust cap on the cylinder valve outlet that is provided with the cylinder valve. Other types of caps or plugs may result in leakage of propane.

Disconnecting A Liquid Propane Gas (LPG) Tank From Your Heater

- Make sure the Burner Valve and LP Gas tank valve are off. (Turn clockwise to close.)
- Detach the hose and regulator assembly from the LP Gas tank valve by turning the Quick Coupling Nut counterclockwise.
- Don't use a wrench or any tools when turning the Quick Coupling Nut.



WARNING



If you have a gas leak that cannot be repaired by tightening. Turn off the gas at the source, disconnect fuel line from your heater and call your gas supplier or a plumber for assistance.

Secure a 20lb LP Gas Tank

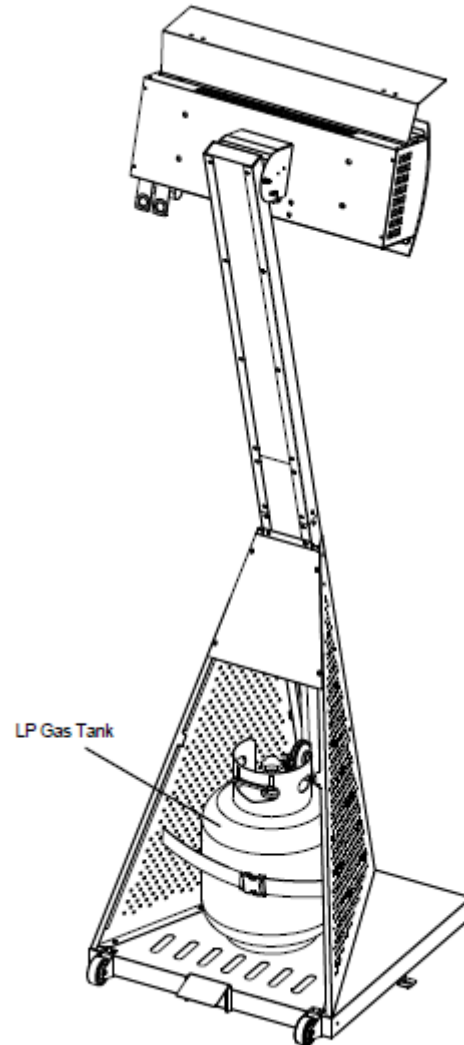

- Turn your LP Gas Tank Valve clockwise to the closed or OFF position.
- Open the Cart Door and release the Tank Fastening strap. Set the Gas Tank securely on the Tank Holder and secure the Tank Fastening Strap. Close the Cart Door



LIGHTING INSTRUCTION

Heater Lighting Instructions

- Before each use, check all hoses for cracks, nicks, cuts, burns or abrasions. If a hose is damaged in any way, do not use your heater before replacing the hose with an authorized part from the Parts List. Also make sure all gas supply connections are securely tightened.
- Familiarize yourself with the safety and Use and Care Instructions in this Manual. Do not smoke while lighting heater or checking gas supply connections.
- Always light the heater standing to the side of the heater, never light the heater standing in front.

WARNING

Failure to replace a faulty hose, secure gas supply connections before proceeding to the Lighting Procedures could result in a fire or explosion that could cause serious bodily injury, death, or property damage.

- (1) Set Control Knob to OFF and open the LP Gas Cylinder valve.



- (2) Pull the trigger "ON" down, "click" will be heard and continue to hold for 10 seconds.
- (3) Once the pilot flame is established, keep pressing the knob for 10 seconds to ensure that the burner remains lit.
- (4) If the burner does not ignite, turn gas off at source and Pull the trigger "OFF" down. Wait at least 5 minutes for gas to clear, then retry. If your heater still fails to light, turn the Control Knob and gas source OFF. Wait 5 minutes for gas to clear and then conduct a gas leak test. If no leaks are detected, repeat the lighting procedure.
5. When the heater is not in use, Pull the trigger "OFF" down and turn off the gas source.

Manually Lighting Your Heater Using A Match

Insert a match into the Lighting Stick, Then open gas source. Light the match and place the Lit match through the Protective Guard to the burner as shown below. Pull the Trigger "ON" down, when the burner lit hold the trigger down for 10 seconds to ensure the burner remain lit.

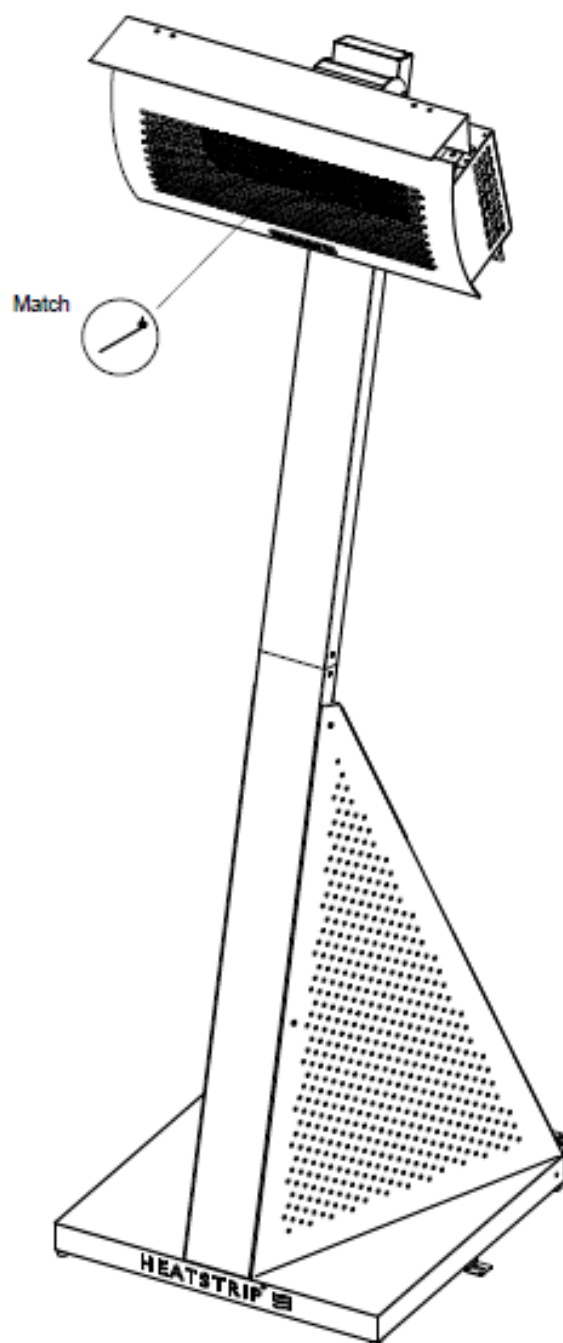

TROUBLE SHOOTING

Fault	Causes	Remedy
Pilot or main burner will not light	(a) Air in gas line	Purge gas line
	(b) Blockage in gas line	Trace back and clear
	(c) Igniter not sparking	Repair lead, electrode, piezo or replace battery
	(d) Cylinder turned off	Turn on
	(e) Cylinder empty	Install full cylinder
Main burner will not light fully	(a) Poor gas supply	Trace supply back to source, clear where necessary
	(b) Gas control inoperative	Inspect valve, rectify
	(c) Insufficient gas	Install full cylinder/rectify gas supply
Flame is yellow	(a) Check injector	Clean if necessary
	(b) Check gas pressure	Adjust as required
	(c) Check venturi for dust	Clean if necessary
	(d) Check burner ports for blockage	Clean if necessary



If the appliance still cannot be lit, contact [800.966.8126](tel:800.966.8126) for assistance.

CLEANING AND MAINTENANCE

Proper care and maintenance will keep your heater in top operating condition and prolong its life. Follow these cleaning procedures on a timely basis and your heater will stay clean and operate with minimum effort.

CAUTION: Be sure your heater is OFF and cool before cleaning.

CLEANING EXTERIOR PAINTED SURFACES

Before initial use, and periodically thereafter, we suggest you wash your heater using a mild soap and warm water solution. You can use a wash cloth or sponge for this process.

Never use abrasive cleaners, scrubbers or stiff wire brushes of any type on your heater. These will scratch painted surfaces during the cleaning process.

Ensure the appliance is dried after cleaning to prevent rusting. It is recommended the heater be operated on high heat after cleaning to ensure the appliance is dry.

WARNING

Failure to comply with these instructions could result in a fire or explosion that could cause serious bodily injury, death or property damage.

Keep heater area clear and free from combustible materials, gasoline and other flammable vapors and liquids.

Keep the ventilation openings of the cylinder enclosure cabinet free and clear of debris.

WARRANTY TERMS

Thermofilm warrants to the original owner that HEATSTRIP products will be free from defects in materials and workmanship for a period of 24 months from the date of purchase in accordance with the following warranty terms and conditions.

Provision of this warranty is subject to:

- The HEATSTRIP products must be installed in accordance with the Installation Instructions and relevant gas and electrical standards and codes.
- The HEATSTRIP products must be maintained and cleaned according to instructions detailed in the Installation Manual.
- There is no warranty expressed or implied with regard to capacity requirements. The selection of the unit or units depends entirely upon the system design and capacities as determined by the purchaser.
- The customer has not repaired, opened or altered the product in any unauthorized manner.
- This warranty excludes damage to the product or components arising from circumstances outside the control of Thermofilm, including, but not limited to, where the product is not used for intended purpose; where the product has been rectified in any way; incorrect installation; incorrect power supply; damaged caused during delivery; misapplication, misuse, abuse, vandalism, lack of maintenance or accident.
- The original invoice, including serial number are required for any claim made pursuant to the terms of warranty.
- Thermofilm is not liable for, and will not authorized repairs resulting from product not performing correctly as a result of being used in an environment where the ambient temperature and humidity are outside the operating conditions specified for these items.
- Transportation charges involved in return of the product to the Thermofilm factory (or any other location authorized in writing by Thermofilm) is the sole responsibility of the customer.

The following are not covered under this warranty

1. Breakage of the burner tiles .
2. Rust and or discoloration due to heat or corrosive environments
3. Damage or failure due to incorrect installation of gas supply.
4. Any damage or loss attributable to failure to provide adequate ventilation for the product as specified by the manufacturer.

Thermofilm does not participate in any site related costs or labour expenses incidental to replacement of parts, repairing, removing, installing, servicing, transportation or handling of parts to complete products, and assumes no liability on parts repaired or replaced without written authorization. Thermofilm shall not be liable for any default or delay in performance of its warranty obligations caused by any circumstances beyond its control, including, but not limited to, judicial or government restrictions, strikes, fires, floods, abnormal weather conditions, delayed supply of components.

Should products be determined as damaged on arrival, immediately notify the transport company of the condition and have them noted on the freight documents. If damage is discovered after unpacking, demand Immediate inspection by the transportation company and insist that a record of the damage is made on the freight documentation.

The customer warrants using the product in accordance with:

1. Any instructions provided to it by Thermofilm from time to time.
2. All government and local regulations, including but not limited to all relevant gas electrical, environmental laws and regulations governing the installation, storage, use, handling and maintenance of the goods.
3. All necessary and appropriate precautions and safety measures relating to the installation, storage, use, handling and maintenance of goods.

Our goods come with guarantees that cannot be excluded under the American Consumer Law. You are entitled to a replacement or refund for a major failure and for compensation for any other reasonably foreseeable loss or damage. You are also entitled to have the goods repaired or replaced if the goods fail to be of acceptable quality and the failure does not amount to a major failure.

All warranty requests for repairs or replacements must be accompanied by a complete "Warranty Claim Form" available from Thermofilm, together with proof of purchase (and where possible, photos of the installation) and the heater returned to the place of purchase.

In the event of a warranty claim, the goods need to be returned to the distributor/retailer for repair replacement.

No part returns will be accepted without prior authorization from AMD Direct

Authorization for parts and/or the return of parts may be requested by calling [800.966.8126](tel:800.966.8126) 9am-4:30pm PST, Monday-Friday.

For technical troubleshooting and/or service inquiries, please call [800.966.8126](tel:800.966.8126) 9am-4:30pm PST, Monday-Friday.