

HEATSTRIP[®]

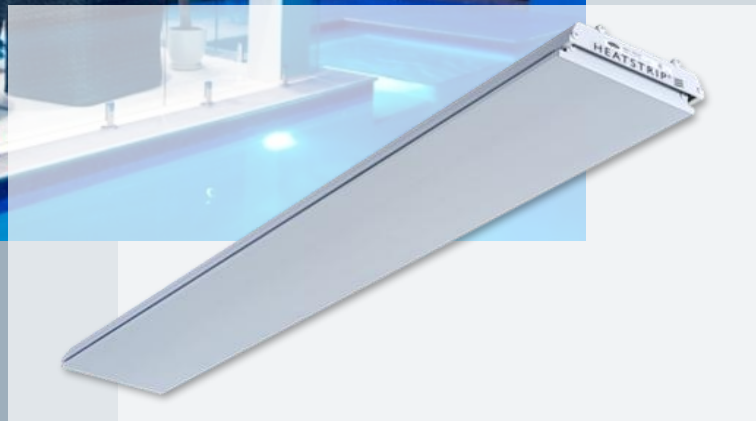

Classic White (X-THHUS-AW) Product Manual



HEATSTRIP[®] Classic White (THHUS-AW)

www.heatstrip.com

US & CANADA

HEATSTRIP[®]



IMPORTANT INSTRUCTIONS

When using electrical appliances, basic precautions should always be followed to reduce the risk of fire, electric shock, and injury to persons, including the following:

1. Read all instructions before installing or using this heater.
2. This heater is hot when in use . To avoid burns, do not let bare skin touch hot surfaces. Keep combustible materials, such as furniture, pillows, bedding, papers, clothes, etc. and curtains at least 3ft (0.9m) from the front of the heater and keep them away from sides and rear restrictions apply to location dedicated heaters only.)
3. Extreme caution is necessary when any heater is used by or near children or invalids and whenever the heater is left operating and unattended.
4. Do not operate any heater after it malfunctions. Disconnect power at service panel and have heater inspected by a reputable electrician before reusing .
5. To disconnect heater, turn controls to off, and turn off power to heater circuit at main disconnect panel (or operate internal disconnect switch if provided)
6. A heater has hot and arcing or sparking parts inside. Do not use it in areas where gasoline, paint, or flammable vapours or liquids are used or stored.
7. Use this heater only as described in this Manual. Any other use not recommended by the manufacturer may cause fire, electric shock, or injury to persons.

“SAVE THESE INSTRUCTIONS”



INSTALLATION

1. This equipment shall be installed only by qualified personnel who are familiar with the construction and operation of the apparatus and hazard involved.
2. The heater is fitted with an electrical connection box and should be connected as a fixed installation by a licensed electrical professional in accordance with the relevant electrical code.
3. Within USA, electrical installation shall be made in accordance with the National Electrical code.
4. Within Canada, electrical installation shall be made according to the provisions of section 62 of the Canadian electrical code Part 1.
5. This appliance must be grounded.
6. An over current protection device (or circuit breaker) is required for proper installation. The rating of the device should be 150% of the rating of the product.
7. The heaters are designed for domestic/ commercial heating applications within indoor or outdoor area and should not be used for any other purpose. Any other use not recommended by the manufacturer may cause fire, electric shock or injury to persons.
8. Before commencing installation make sure the electrical supply voltage is the same as that shown on the rating plate of the heater.
9. The heater must be mounted at least 6ft (1.8m) above ground level when installed in USA and 8ft (2.4m) above ground level when installed in Canada . For other clearances please refer to the diagram included in these instructions.
10. Do not use heater in areas where gasoline, paint or flammable liquids are used or stored.
11. Do not operate the heater after the heater malfunctions, or has been dropped or damaged in any manner. Return heater to authorised service facility for examination or mechanical adjustment or repair.
12. There are no user serviceable parts inside the heater any servicing other then cleaning of the heater should be performed by an authorised service representative

CAUTION:

High temperature risk of fire, keep electrical cords, drapery, furnishings and other Combustibles At least 3ft (0.9m) from front of heater and away from side and rear of heater.

HEATSTRIP®



Specifications - US & Canada

MODEL	VOLTAGE (V)	POWER (Watts)	CURRENT (Amps)	DIMENSIONS (mm / in)	WEIGHT (kg / lb)	CONNECTION	HEATING AREA (m ² x ft ²)
X-THH2400US-AW (240V)	240	2400	10	1364 x 165 x 48mm 53 11/16" x 6 1/2" x 1 7/8"	7kg 15lb	Gang Box	4-5m ² 43-54ft ²
X-THH3200US-AW (240V)	240	3200	13.3	1774 x 165 x 48mm 69 13/16" x 6 1/2" x 1 7/8" in	9kg 20lb	Gang Box	5-6m ² 54-65ft ²

MODEL							
HEATER TYPE	Electric radiant overhead heater with high surface area profiled alloy						
OUTPUT	Refer to model code chart above						
POWER	120, 208 or 240 Volts Nominal at 50—60 Hertz, Single Phase						
CONNECTION	½" NPT connection enclosure						
APPROVALS							
MOUNTING HEIGHT	<table border="0"> <tr> <td>MINIMUM</td> <td>82 11/16" (2.1 m)</td> </tr> <tr> <td>RECOMMENDED</td> <td>7' 6½" - 98 7/16" (2.3 m to 2.5 m)</td> </tr> <tr> <td>MAXIMUM</td> <td>106 5/16" (2.7 m)</td> </tr> </table> For higher ceiling heights, units can be lowered using optional extension pole mounting kits	MINIMUM	82 11/16" (2.1 m)	RECOMMENDED	7' 6½" - 98 7/16" (2.3 m to 2.5 m)	MAXIMUM	106 5/16" (2.7 m)
MINIMUM	82 11/16" (2.1 m)						
RECOMMENDED	7' 6½" - 98 7/16" (2.3 m to 2.5 m)						
MAXIMUM	106 5/16" (2.7 m)						
MOUNTING OPTIONS	Suitable for ceiling, wall, beam and recess mounting. Also available for extension mount using rigid fixing poles and chain mount bracket.						
PROTECTION RATING	IP55 Protection from water ingress from all directions						
COUNTRY OF MANUFACTURE	China						

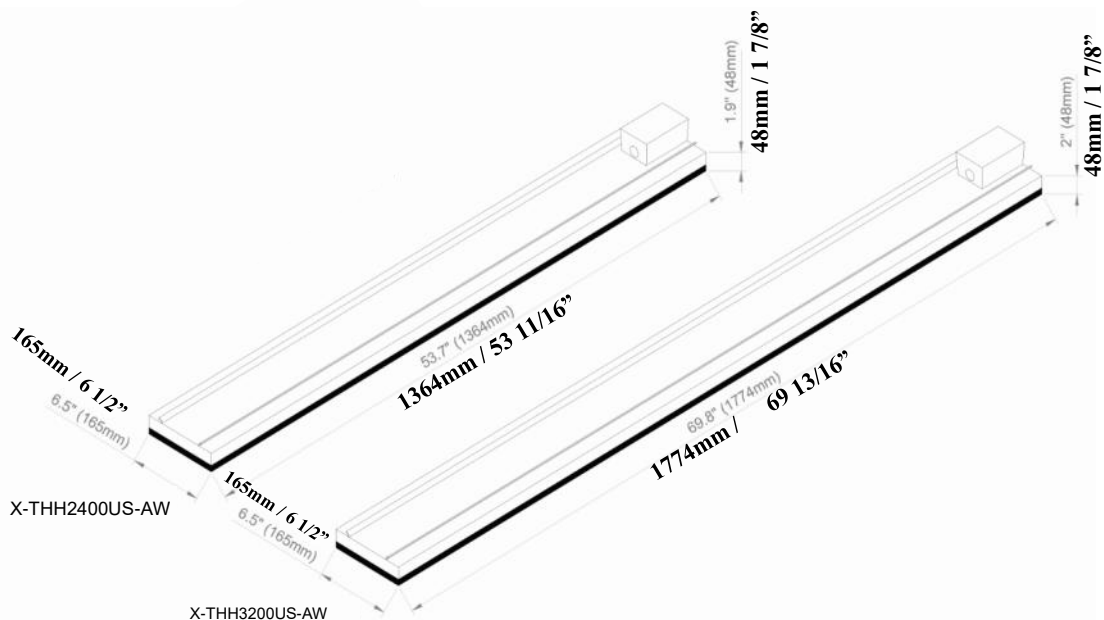



Spot heating principle

In most outdoor or difficult-to-heat indoor applications, there are 2 options when looking at the size and quantity of the heaters required.

Option 1 is to comfort heat the entire area based on the total dimensions of the space, regardless of whether the entire area is being fully occupied.

Option 2 is to spot heat the high use areas, such as over outdoor tables, BBQ's, lounges, assembly lines or indoor work-stations.

Often it is more practical and efficient to spot heat high use areas. Spot heating will reduce both the initial capital cost as well as the ongoing running costs. Spot heating will allow the area to be "zoned", meaning only the areas that are being used are heated, such as tables in a restaurant or outdoor alfresco area.

Option 1 and 2 show a comparison between heating an entire area or spot heating over a table.

The bottom layout shows the flexibility of using HEATSTRIP® to provide a comfortable environment, even when the layout of the area is very unusual.

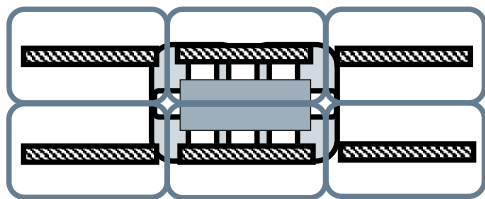

Option 1: 6 x X-THH2400US-AW

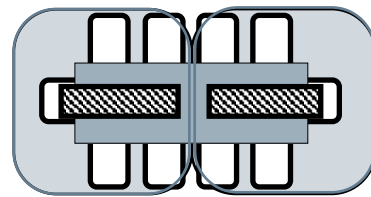

Option 2: 2 x X-THH3200US-AW

Proposed Outdoor Area layout

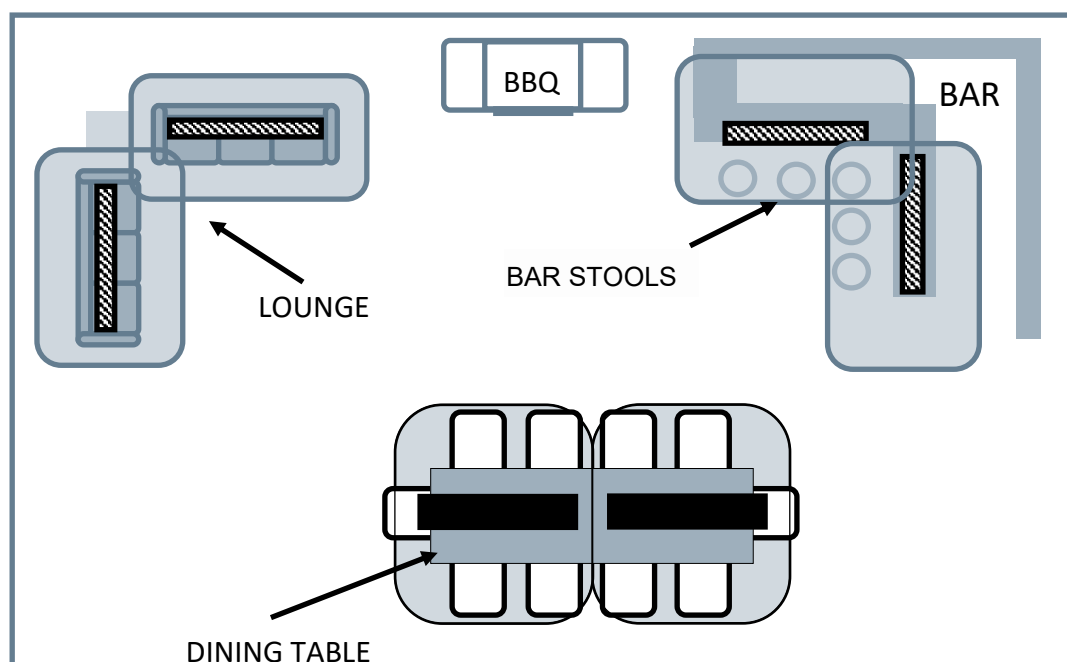



Radiant footprint

HEATSTRIP® electric heaters produce radiant heat which heats objects rather than the air. Therefore, it is imperative that objects to be heated (ie. people), are within the direct radiant footprint of the heater.

The diagram to the left shows the radiant footprint of HEATSTRIP® Classic, and is an approximate guide based on a fully enclosed outdoor environment.

This diagram shows that the maximum heat output is found directly under the heater, and the temperature decreases as you move away from the heater.

It highlights the importance of maintaining recommended mounting heights, and if possible, positioning the heater directly above the area to be heated.

Note that the temperature is the same for all 2 models, regardless of the wattage. However, as the size increases and the length of the unit increases, the radiant footprint will be longer.

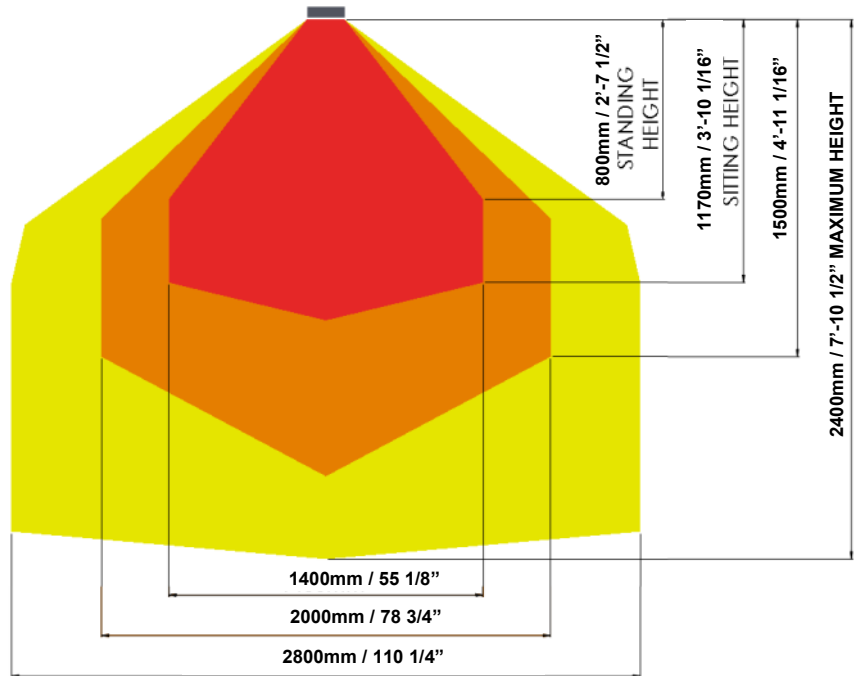

The below diagrams show the approximate heating area for each model, based on both an indoor and outdoor enclosed environment, with direct overhead mounting.

The radiant footprint is reduced in angled, wall mounted installations.

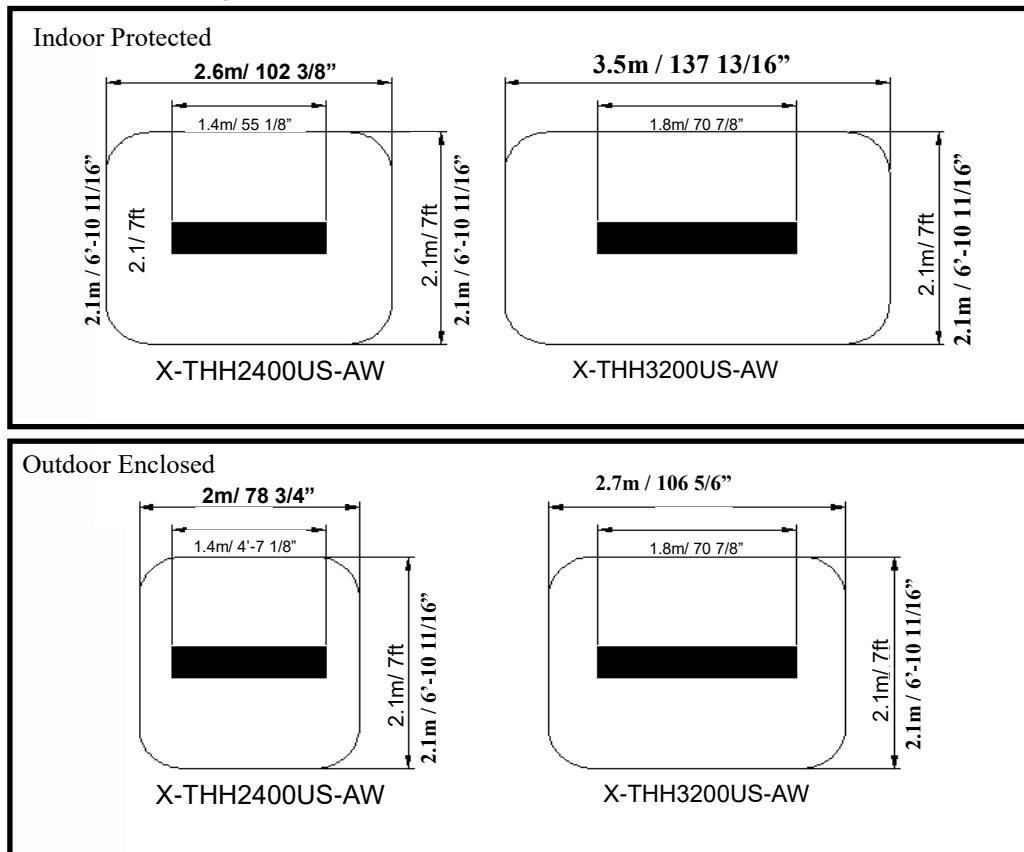



Selection guide

General recommendations for **HEATSTRIP® Classic White**:

Ideal mounting height: 2.3m to 2.5m (7' 6½" - 98 7/16"). Maximum is 2.7m 98 7/16" in a fully protected/ enclosed outdoor environment.

- Ideal mounting location: ceiling mounted, directly above area to be heated (eg. above a table)
- Based on the radiant footprint of the previous page, for a protected outdoor area, a minimum of 500W/m² (46W/ft²) is required. For indoor spot heating, a minimum heating capacity of 400W/m² (37W/ft²) is recommended.

The table below outlines the coverage of each **HEATSTRIP® Classic White** model based on 3 different scenarios with direct overhead mounting. For example, for an outdoor area that is protected from prevailing winds by walls, café blinds etc, Model THH2400US-AW will cover 4.8m² / 52ft².

For angled wall mounting applications, the coverage is reduced by up to 40%.

MODEL	INDOOR PROTECTED (m ² /ft ²)	OUTDOOR ENCLOSED (m ² /ft ²)	OUTDOOR EXPOSED (m ² /ft ²)
X-THH2400US-AW	6m ² / 65ft ²	4.8m ² / 52ft ²	3.9m ² / 43ft ²
X-THH3200US-AW	8m ² / 86ft ²	6.4m ² / 69ft ²	5.2m ² / 57ft ²

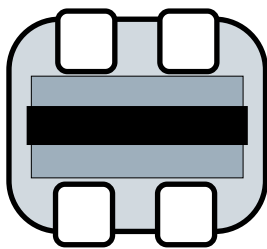



Table layout

For the majority of outdoor applications, the most effective method is to spot heat a table or similar area. The diagrams below provide an easy selection guide for the approximate model and quantity of heaters required to heat common residential table settings.

Selections are based on HEATSTRIP® Classic being mounted at 2.4m / 8ft from the floor in a fully enclosed under-cover outdoor area.



1 x X-THH2400US-AW

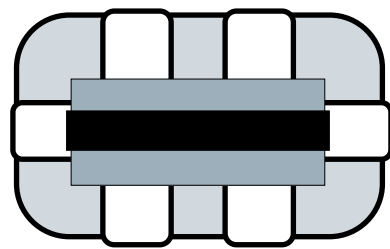

1 x X-THH3200US-AW

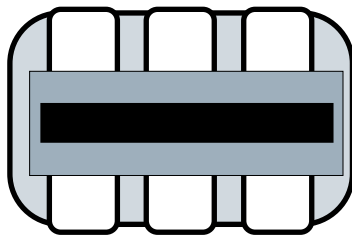

1 x X-THH3200US-AW

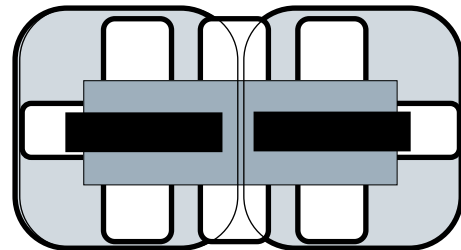

2 x X-THH2400US-AW

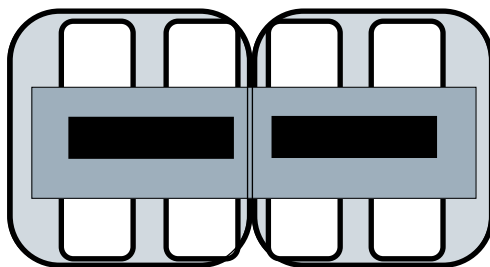

2 x X-THH2400US-AW

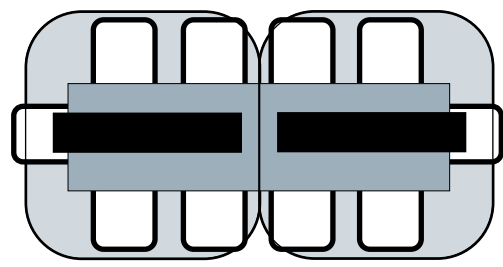

2 x X-THH3200US-AW

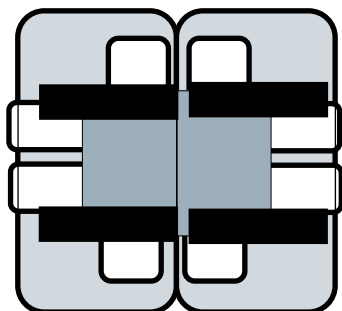

4 x X-THH2400US-AW

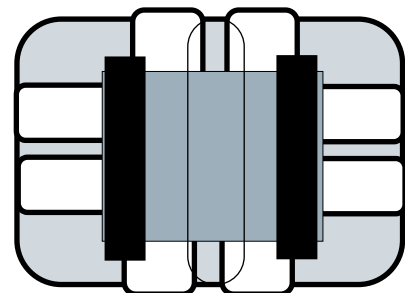

2 x X-THH3200US-AW





Installation Requirements

The ideal mounting position for the HEATSTRIP® Classic White is on the ceiling directly above the area to be heated. If this is not possible, HEATSTRIP® can be mounted on a wall and angled downwards. In this situation, ensure the mounting height is in the range of 2.1m / 6'-10 11/16" to 2.7m / 8'-10 5/16" and the table is within 2.5m / 8'-2 7/16" of the wall.

For mounting heights more than 2.7m/8.8ft, we recommend the use of the optional accessories to reduce the height of the heater to 2.3m / 7'-6 9/16" — 2.5m / 8'-2 7/16". This will increase the effectiveness of your HEATSTRIP®. Refer to the Mounting Accessory section for more information.

Electrical connections/GPO's should not be located at the back of the heater. They should be located outside the physical footprint of the units to minimize heat build-up behind the units.

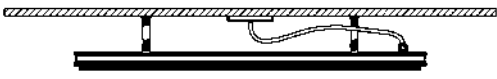
If the heater is to be mounted on an incline (e.g. vaulted ceiling), ensure the electrical connection is located at the lowest point of the heater.

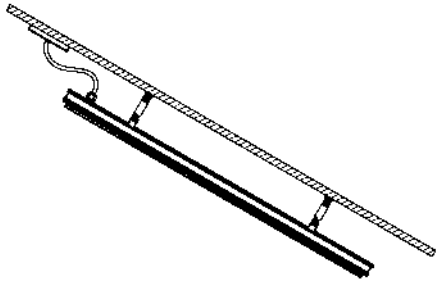
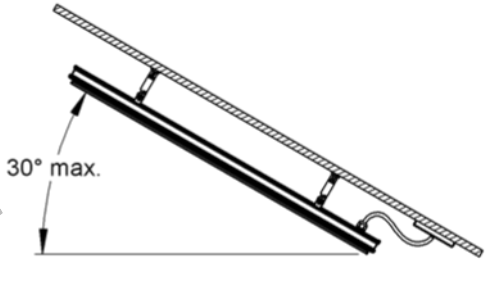
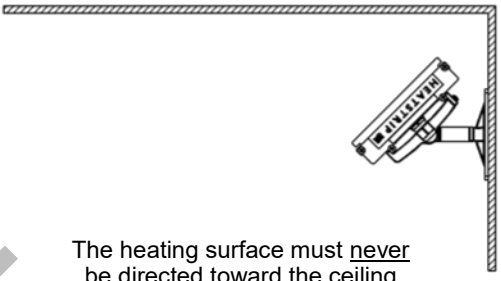
Incorrect Installation	Correct Installation
	
	
 <p data-bbox="311 1915 654 1971">The heating surface must <u>never</u> be directed toward the ceiling</p>	

HEATSTRIP®



Installation location — the diagrams below provide the minimum recommended clearances in mm.

WARNING: This heater is not equipped with a device to control the room temperature. Do not use this heater in small rooms when they are occupied by persons not capable of leaving the room on their own, unless constant supervision is provided.

Angled Wall Installation

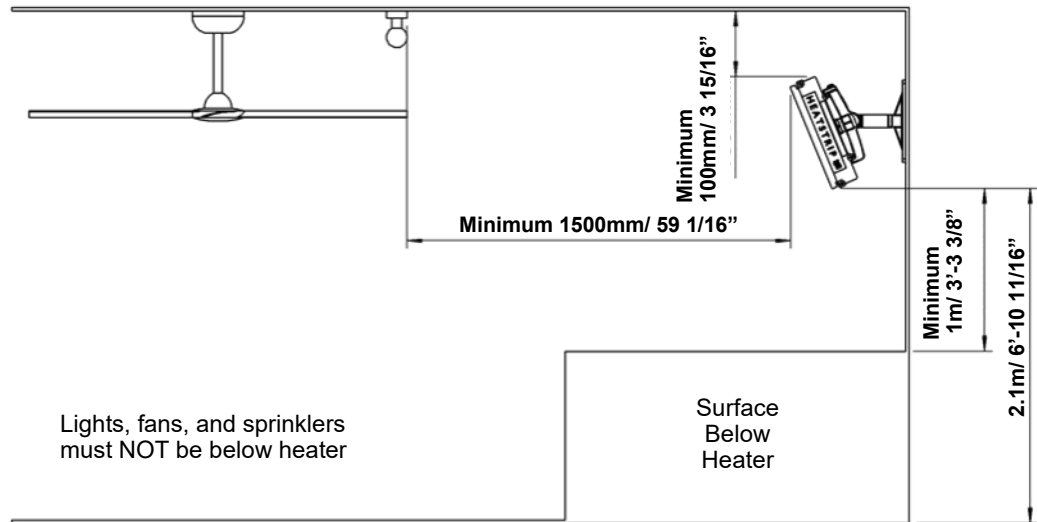

Ceiling Installation

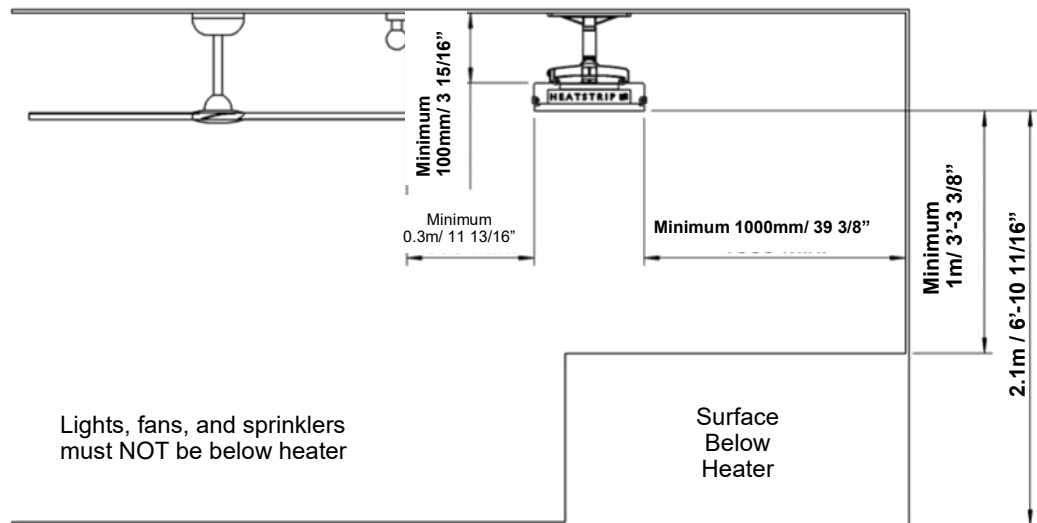

Angled Ceiling Installation

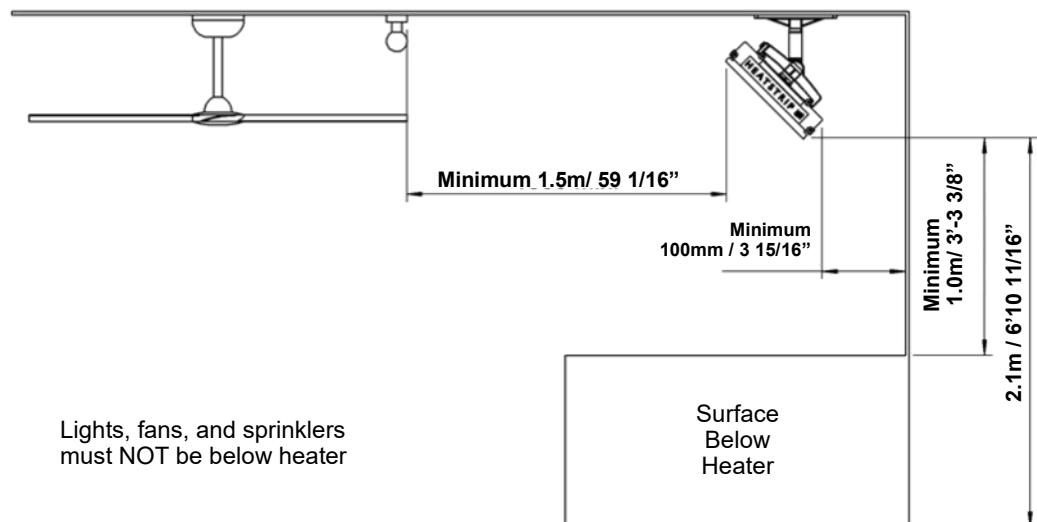



Mounting options

Installing the HEATSTRIP® Classic is simple and easy using the standard mounting brackets supplied. For other irregular locations there are range of mounting options available - refer to diagrams below

The HEATSTRIP® Classic can be mounted directly to the ceiling, angled downwards on a wall, fitted flush with the ceiling, suspended on chains or poles, attached to beams or poles, mounted end-to-end. Refer to the following pages for more detailed information on each mounting option.

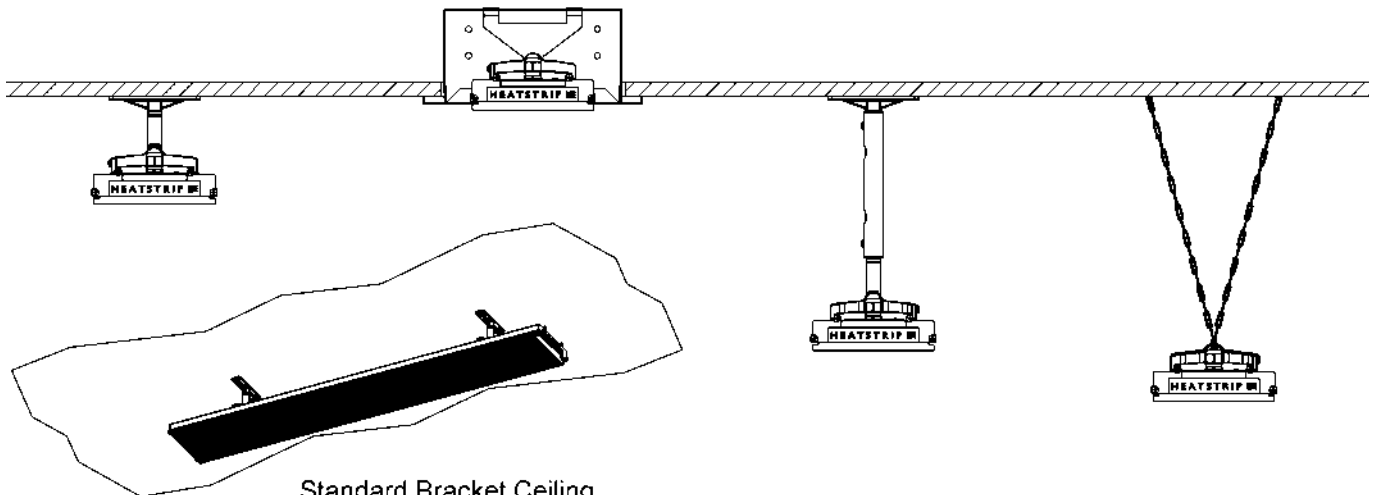

Standard Bracket Ceiling

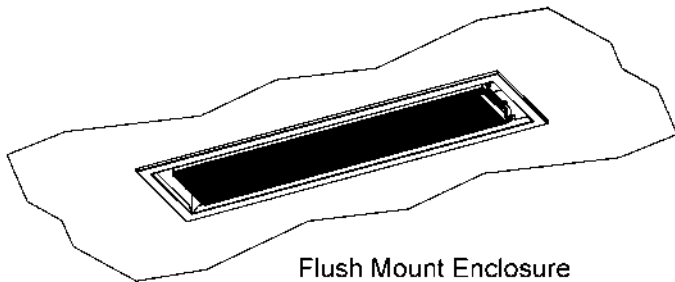

Flush Mount Enclosure

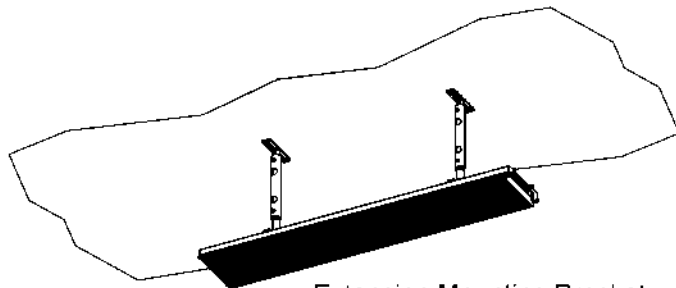

Extension Mounting Bracket

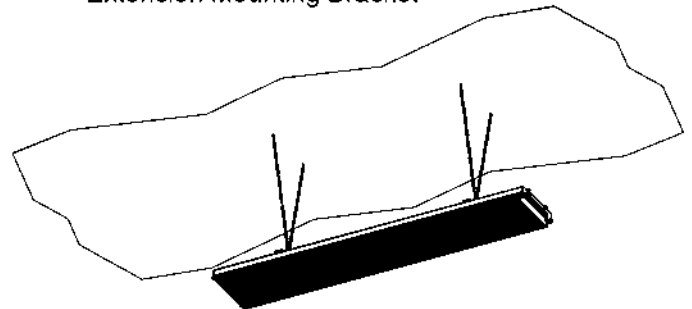

Chain / Wire Mounting

HEATSTRIP®



Standard mounting brackets

The HEATSTRIP® Classic comes with a pair of standard mounting brackets. These adjustable brackets allow direct ceiling or wall mount, and come with preset angle options of parallel, 22.5° and 45°.

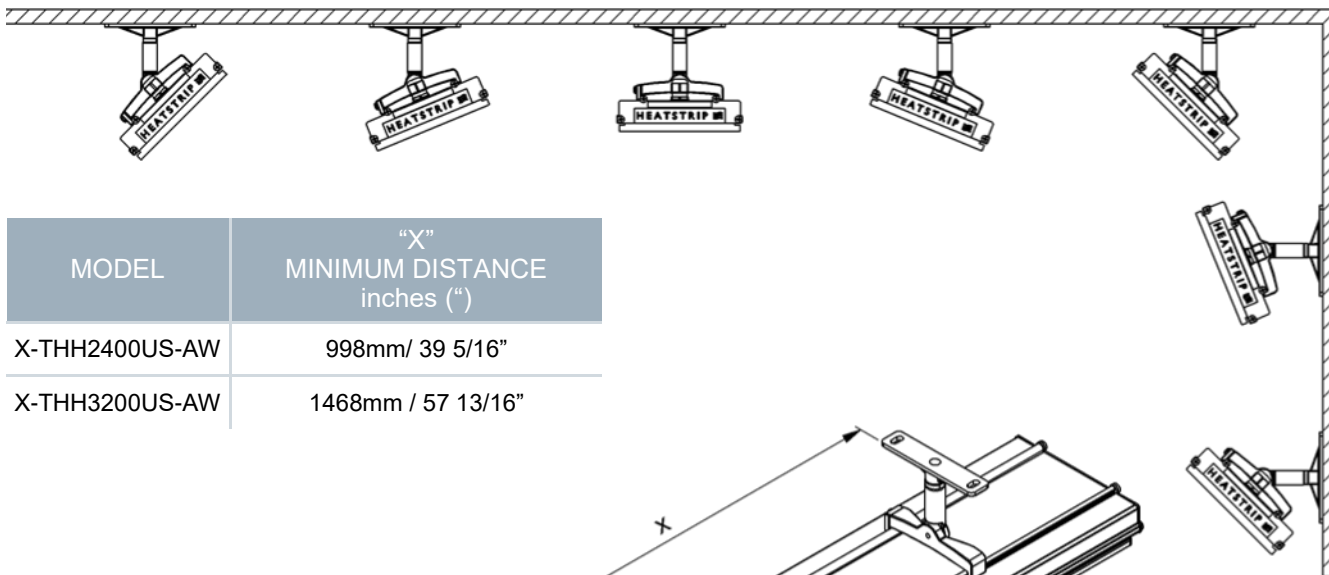

MODEL	"X" MINIMUM DISTANCE inches (")
X-THH2400US-AW	998mm/ 39 5/16"
X-THH3200US-AW	1468mm / 57 13/16"

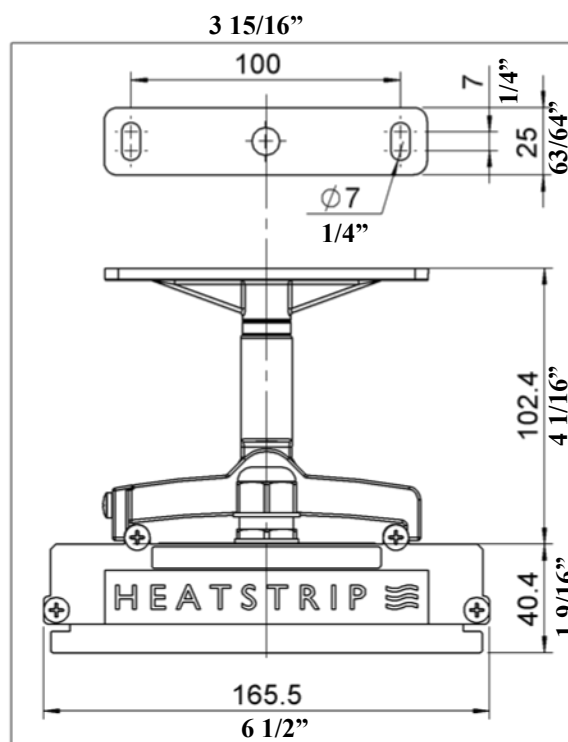
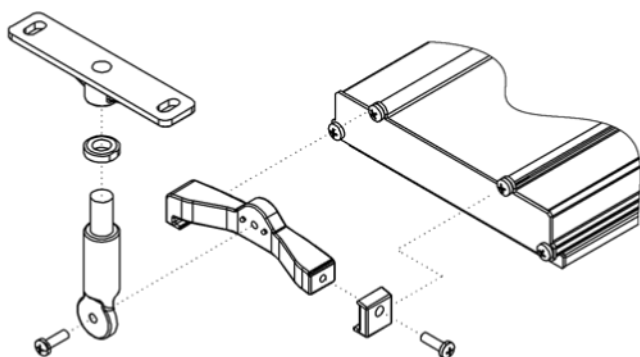
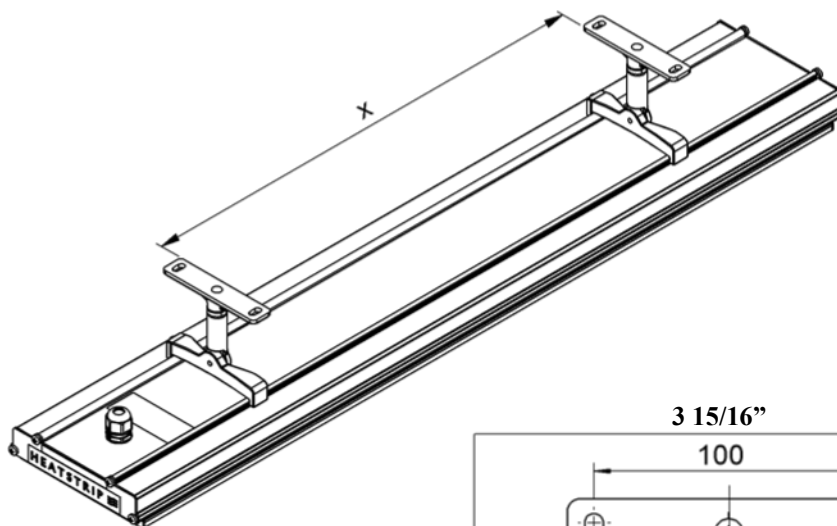

PART No	PACKAGED DIMENSIONS (mm/inch)	WEIGHT (lbs)	MATERIAL
ZBRAK-113W	125 x 150 x 40mm 4 15/16" x 5 7/8" x 1 9/16"	0.44	ALLOY



Flush mount enclosure

The Flush Mount Enclosure is an ideal way to neatly install the HEATSTRIP® into a ceiling. They are available for all HEATSTRIP® Classic models, and are supplied as a one-piece unit suitable for mounting individual heaters. Flush mounting can be used with plaster or timber lined ceiling materials.

An ideal mounting height is 2.3m-2.5m (7'-6 9/16" to 8'-2 7/16"), with a maximum ceiling height of 2.7m / 8'-10 5/16" in an outdoor enclosed environment. Maximum mounting heights should be strictly followed, otherwise the performance of the units may be reduced.

The fascia of the enclosure is manufactured from 316 Stainless Steel and the rear casing is black zinc coated steel.

Please refer to the Flush Mount Enclosure Installation Manual for more detailed installation information.

SUITABLE FOR MODELS	PART No	HOLE CUTOUT DIMENSIONS (mm / inches)	OVERALL DIMENSIONS (mm/inches)	WEIGHT (kg/lbs)
X-THH2400US-AW	THHAC-011	1420 x 230mm 55 7/8" x 9 1/16"	1470 x 280 x 125 4'-9 7/8" x 11 1/32" x 4 15/16"	8kg / 17lbs
X-THH3200US-AW	THHAC-012	1830 x 230mm 72 1/16" x 9 1/16"	1880 x 280 x 125 74 1/64" x 11 1/32" x 4 15/16"	9kg / 19 lbs

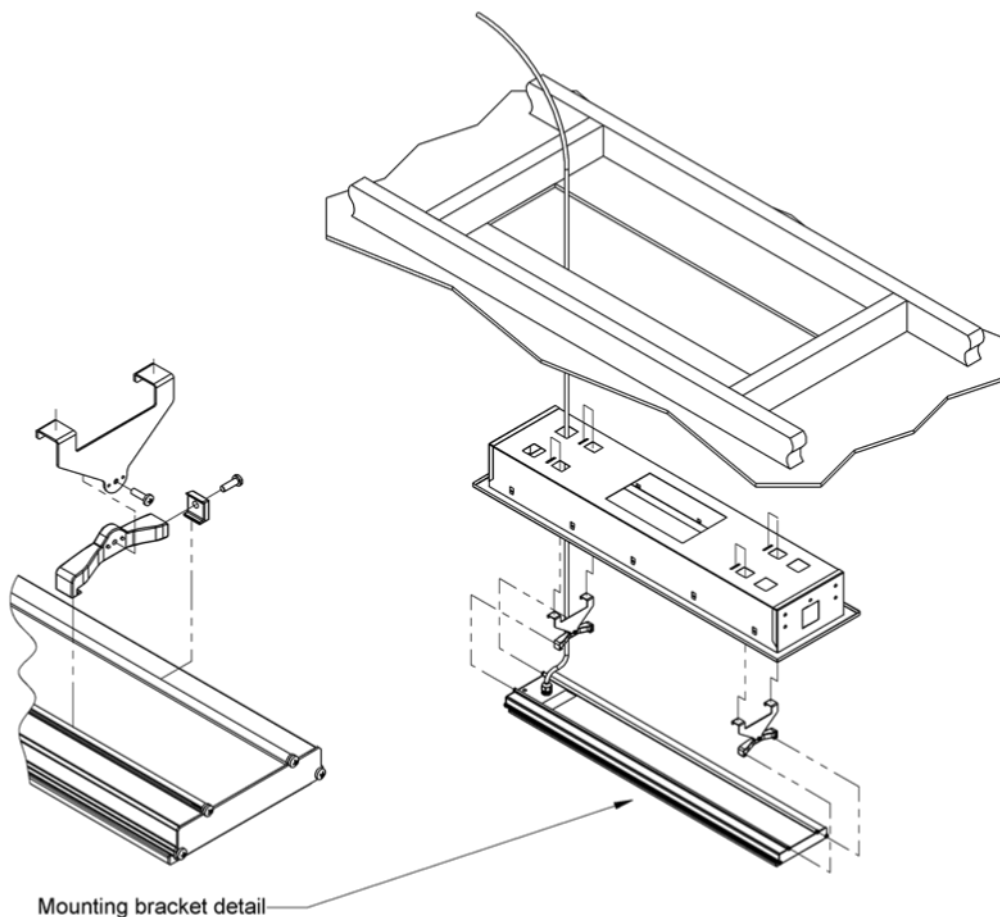



Extension Mount Bracket

The Extension Mount bracket allows HEATSTRIP® Classic units to be lowered from high ceilings using rigid connections. The brackets are designed to be used with 20mm x 20mm x 1mm tube (SHS), and can be supplied as brackets only for customising the length of the drop on site, or supplied as a complete kit with brackets, pre-cut poles and connections. The standard length options as part of the kit are (standard mounting bracket) 100mm (4"), 300mm (12"), 600mm (24"), 900mm (36") and 1200mm (48").

The extension mount brackets utilise components from the standard bracket kit which is supplied with each heater.

*screws to ceiling are not included

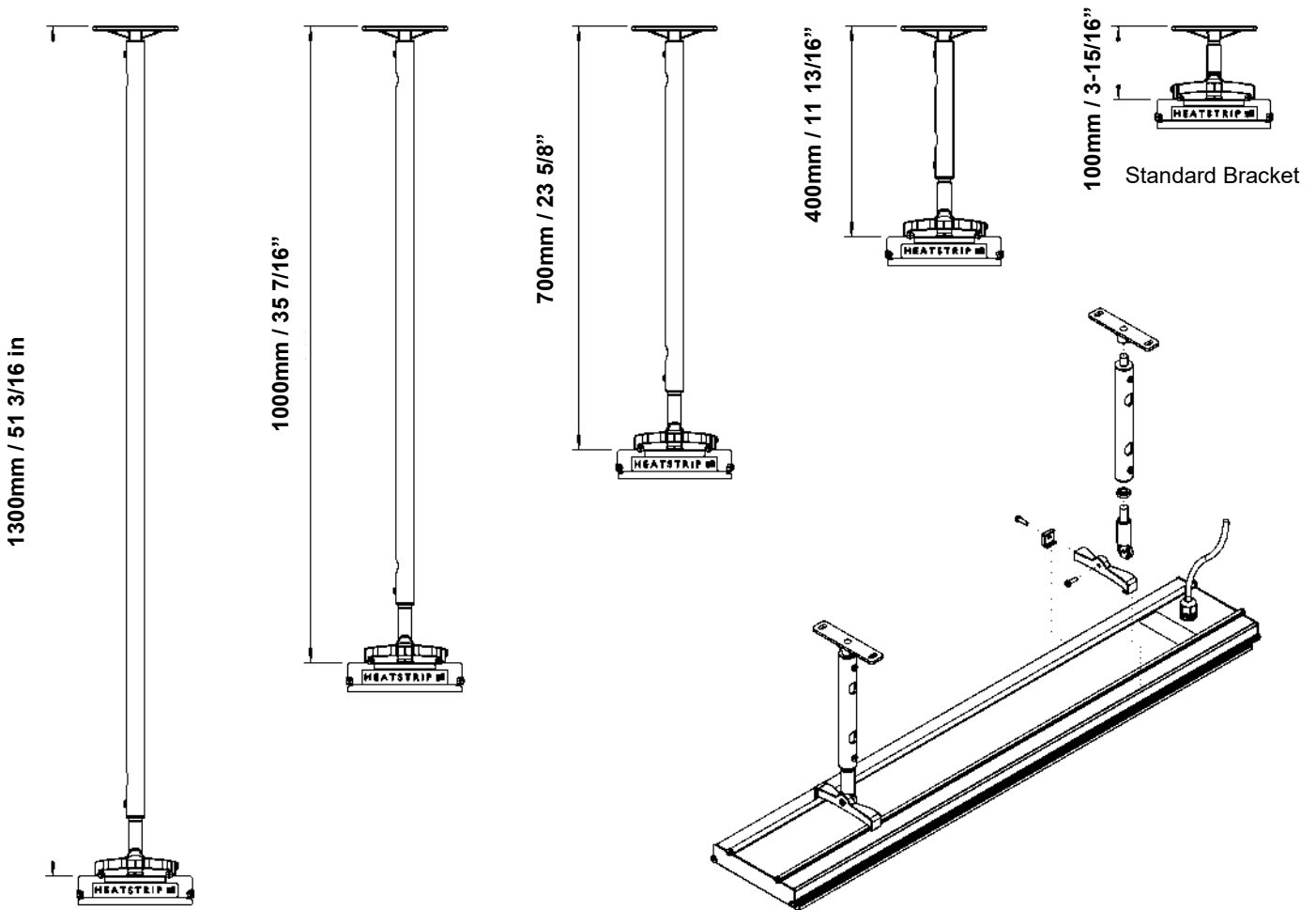

PART No	PACKAGED DIMENSIONS (mm)	WEIGHT (lbs)	MATERIALS	NOTES
THEAC-043	11 13/16" x 5 7/8" x 1 15/16" (300 x 150 x 50mm)	5 lbs (2 kgs)	ALLOY	Kit includes 2 x 300mm / 11 13/16" extension pole
THEAC-044	23 5/8" x 5 7/8" x 1 15/16" (600 x 150 x 50mm)	5 lbs (2 kgs)	ALLOY	Kit includes 2 x 600mm / 23 5/8" extension pole
THEAC-045	35 7/16" x 5 7/8" x 1 15/16" (900 x 150 x 50mm)	6 lbs (2.5 kgs)	ALLOY	Kit includes 2 x 900mm / 35 7/16" extension pole
THEAC-046	47 1/4" x 5-7/8" x 1-15/16" (1200 x 150 x 50mm)	7 lbs (3 kgs)	ALLOY	Kit includes 2 x 1200mm / 47 1/4" extension pole



Wiring Schematic

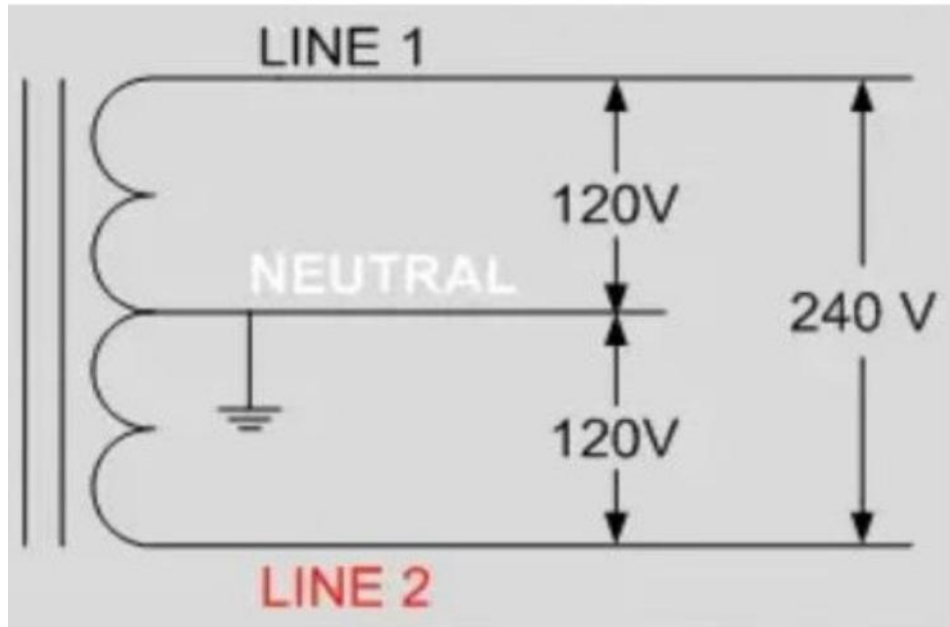

The entry line in North America is a single-phase three wire system, with 120V between L and N and 240V between L1 and L2.

Run another circuit with 2 live wires (to use 240VAC) + Ground wire.

- Live 1 connect to L
- Live 2 connect to N (mark label L2 on N terminal). Don't connect Neutral wire to N terminal,
- Ground wire connects to G

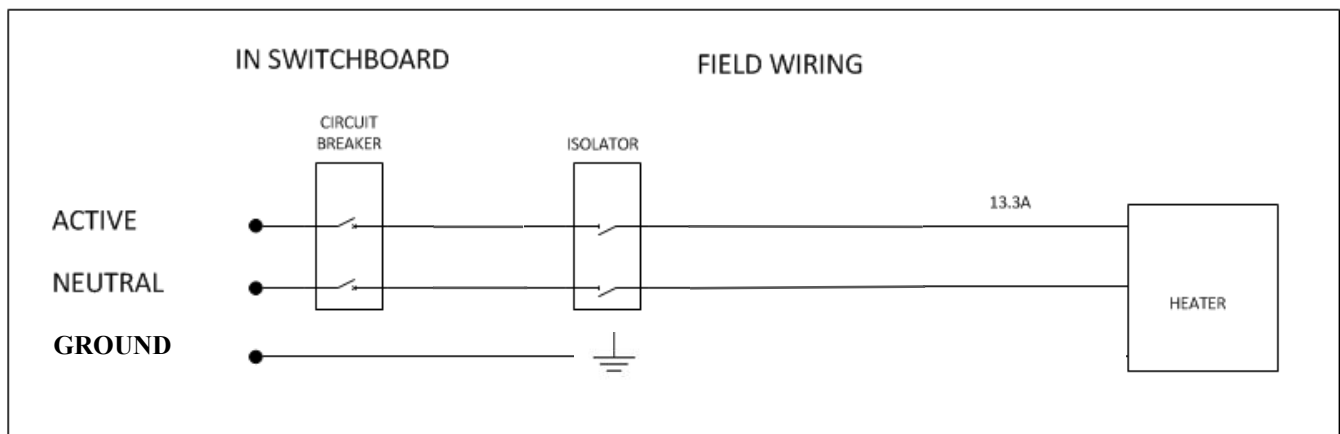



Safety

HEATSTRIP[®] Classic has an IP rating of 55. This means it is safe for water ingress from all directions.

The HEATSTRIP[®] can be safely hosed down.

HEATSTRIP[®] has undergone extensive testing both in laboratory conditions, in field trials in Australia and overseas. It is this testing that gives the purchaser the confidence of a high quality product.

Independent laboratory testing has confirmed Thermofilm's full compliance with Australian and other International Standards including CE, AS/ANZ, UL/CSA

The heater comes in 2400W and 3200W versions. In all events the fixed wiring must be installed by a licensed electrician in accordance with the relevant wiring regulations.

In operation, this heater is VERY HOT— do not touch any part of the heater while it is turned on. Do not touch any part until 30 minutes after it is turned off.

This appliance is not intended for use by persons (including children) with reduced physical, sensory or intellectual capabilities, or lack of experience and knowledge, unless they have been given supervision or instruction concerning use of the appliance by a person responsible for their safety. Children should be supervised to ensure they do not play with the appliance.

Do not allow any cables, furnishings, flammable materials or other items come in contact with any surface of the heater.

If installed in wet areas, the heater switches or controls must be located so that they cannot be touched by persons in the bath or shower.

The heater needs to be installed as per the installation instructions paying special attention to the minimum clearances. The heater needs to be mounted on a rigid bracket or fixing.

The heater must not be mounted immediately below or in front of a socket outlet.

In case of a heater fault or damaged supply lead, the appliance should be returned to the point of purchase for return to Thermofilm for repair.

Maintenance

The HEATSTRIP[®] Classic is made from durable materials, however regular care and maintenance of your heater will help prolong the life of the heater.

It is recommended that you give a light spraydown the heater and with a soft cloth gently wipe the surfaces of the heater with a warm water to remove the built up contaminants from the environment. Then rinse all detergent off the heater. All chemicals in the atmosphere including cigarette smoke, pollution etc. will tarnish the surface of the heater. In this case, additional cleaning and maintenance may be required. Carrying out the cleaning process at least every three months will reduce the amount of build up and keep the Heatstrip in good condition. If the heater is in a corrosive environment eg. salt spray, we recommend that you clean your heater with a light spray of fresh water every week. After cleaning, turn the heater on for 20 minutes to dry any water residue and prevent water staining.

Before cleaning or inspection activity, the heater must be switched off and cooled down completely.

Do not use any abrasive materials or products to clean the heater, this includes solvents, citrus based cleaners or other harsh cleaning products.

When handling the heater, ensure that your hands are clean or that you use clean gloves as grease or dirt can mark the surface of the heater.

Do not use high pressure water to clean heaters, light water spray only.

HEATSTRIP[®]



SYMPTOM	REASON	CHECK END USER	CHECK TECHNICIAN	FIX
Freight damage	Damaged during transport	Inspect units for damage	Take photos of packaging and unit and return to factory	Return to factory for repair/replacement
Missing brackets	Parts missing from box			Contact factory for replacement brackets
Not heating	No power to unit or unit has short circuited	Check that there is power to the unit	Check the resistance across the active and neutral terminals	Return to factory for repair/replacement
	Cable is damaged	Inspect cable for cuts, scratches, nicks etc.		Return to factory for repair/replacement
Not hot enough	Not enough power to the unit		Electrician to check there is sufficient voltage and current to the unit	Wire correctly with correct current
	Did not wait for the unit to warm up	Wait 15 minutes for the temperature to reach its maximum		Normal Operation
	Multiple units are connected in series not in parallel and not getting enough power		Check the circuit that each one has been wired separately with the correct voltage and current	Wire correctly with correct current
Take too long to heat up	Insufficient power to the unit		Check the voltage and current to the units	Increase power
Discolouration/face of the unit is browning	Heater is over heating		Check that the power supplied matches the rated power on the compliance plate	Replace heater with correctly rated heater
	Environmental factors			Clean heater according to the Cleaning and Maintenance instructions
	This is normal wear for the heater.			Paint the face of the unit using a 700 degree high temperate engine black paint. Available from automotive stores. We can not send these out as aerosols can not be sent in the post



Warranty Terms & Conditions

The below Warranty Terms and Conditions apply for **International Customers**.

Thermofilm warrants to the original owner that HEATSTRIP[®] Classic products will be free from defects in materials and workmanship for a period of 3 years residential & 2 years commercial from the date of purchase in accordance with the following warranty terms and conditions.

Provision of this warranty is subject to:

- The HEATSTRIP[®] product must be installed in accordance with the Installation Instructions and relevant electrical standards and codes.
- The HEATSTRIP[®] product must be maintained and cleaned according to instructions detailed in the Installation Manual.
- There is no warranty expressed or implied with regard to capacity requirements. The selection of the unit or units depends entirely upon the system design and capacities as determined by the purchaser.
- The customer has not repaired, opened or altered the product in any unauthorised manner.
- This warranty excludes damage to the product or components arising from circumstances outside the control of Thermofilm, including, but not limited to, where the product is not used for intended purpose; where the product has been rectified in any way; incorrect installation; incorrect power supply; damaged caused during delivery; misapplication, misuse, abuse, vandalism, lack of maintenance or accident.
- Thermofilm's obligations under this warranty are limited to repair or replacement at Thermofilm's factory of any components of the product which Thermofilm identifies to its satisfaction to be defective.
- Transportation charges involved in return of the product to the Thermofilm factory (or any other location authorised in writing by Thermofilm) is the sole responsibility of the customer.
- All products are inspected and tested before despatch and are at the risk of the purchaser after the shipment from the Thermofilm factory, if not delivered by Thermofilm to destination.
- Discolouration of the surface may occur after a period of time, this does not constitute a warrantable event.
- Twisting and bending of the heaters may occur, this does not constitute a warrantable event.
- No products or components will be supplied in advance of an examination of the faulty product or components by Thermofilm or an authorized representative of Thermofilm.
- Thermofilm does not participate in any site related costs or labour expenses incidental to replacement of parts, repairing, removing, installing, servicing, transportation or handling of parts to complete products, and assumes no liability on parts repaired or replaced without written authorisation. Thermofilm shall not be liable for any default or delay in performance of its warranty obligations caused by any circumstances beyond its control, including, but not limited to, judicial or government restrictions, strikes, fires, floods, abnormal weather conditions, delayed supply of components.

Should products be determined as damaged on arrival, immediately notify the transport company of the condition and have them noted on the freight documents. If damage is discovered after unpacking, demand immediate inspection by the transportation company and insist that a record of the damage is made on the freight documentation.

The customer warrants using the product in accordance with:

- Any instructions provided to it by Thermofilm from time to time.
- All government and local regulations, including but not limited to all relevant electrical, environmental laws and regulations governing the installation, storage, use, handling and maintenance of the goods.
- All necessary and appropriate precautions and safety measures relating to the installation, storage, use, handling and maintenance of goods.

All warranty requests for repairs or replacements must be accompanied by a complete "Warranty Claim Form" available from Thermofilm, together with proof of purchase (and where possible, photos of the installation) and the heater returned to the place of purchase.

Website: Heatstrip.com

Address: 1600 Riverfork Drive East,
Huntington, IN 46750

Phone: 720-470-7930

Email: brand-architect@heatstrip.com