

HEATSTRIP®

Intense with Remote & App Control
(THBBA-UL)
Product Manual



HEATSTRIP® Intense with Remote & App Control

www.heatstrip.com

US & CANADA

HEATSTRIP[®]



IMPORTANT INSTRUCTIONS

When using electrical appliances, basic precautions should always be followed to reduce the risk of fire, electric shock, and injury to persons, including the following:

1. Read all instructions before installing or using this heater.
2. This heater is hot when in use . To avoid burns, do not let bare skin touch hot surfaces.
Keep combustible materials, such as furniture, pillows, bedding, papers, clothes, etc. and curtains at least 3 feet (0.9mm) from the front of the heater and keep them away from sides and rear restrictions apply to location dedicated heaters only.)
3. Extreme caution is necessary when any heater is used by or near children or invalids and whenever the heater is left operating and unattended.
4. Do not operate any heater after it malfunctions. Disconnect power at service panel and have heater inspected by a reputable electrician before reusing .
5. To disconnect heater, turn controls to off, and turn off power to heater circuit at main disconnect panel (or operate internal disconnect switch if provided)
6. A heater has hot and arcing or sparking parts inside. Do not use it in areas where gasoline, paint, or flammable vapours or liquids are used or stored.
7. Use this heater only as described in this Manual. Any other use not recommended by the manufacturer may cause fire, electric shock, or injury to persons.

“SAVE THESE INSTRUCTIONS”

HEATSTRIP[®]



INSTALLATION

1. This equipment shall be installed only by qualified personal who are familiar with the construction and operation of the apparatus and hazard involved.
2. The heater is fitted with an electrical connection box and should be connected as a fixed installation by a licensed electrical professional in accordance with the relevant electrical code.
3. Within USA, electrical installation shall be made in accordance with the National Electrical code.
4. Within Canada, electrical installation shall be made according to the provisions of section 62 of the Canadian electrical code Part 1.
5. This appliance must be grounded.
6. An over current protection device (or circuit breaker) is required for proper installation. The rating of the device should be 150% of the rating of the product.
7. The heaters are designed for domestic/ commercial heating applications within indoor or outdoor area and should not be used for any other purpose. Any other use not recommended by the manufacturer may cause fire, electric shock or injury to persons.
8. Before commencing installation make sure the electrical supply voltage is the same as that shown on the rating plate of the heater.
9. The heater must be mounted at least 6 feet(1.8m) above ground level when installed in USA and 8 feet (2.4) above ground level when installed in Canada . For other clearances please refer to the diagram included in these instructions.
10. Do not use heater in areas where gasoline, paint or flammable liquids are used or stored.
11. The heater is not intended for use in bathrooms, laundry areas or similar indoor areas. Never locate heater where it may fall into a bathtub, pool, spa or other water container.
12. Do not operate the heater after the heater malfunctions, or has been dropped or damaged in any manner. Return heater to authorised service facility for examination or mechanical adjustment or repair.
13. There are no user serviceable parts inside the heater any servicing other then cleaning of the heater should be performed by an authorised service representative

CAUTION:

High temperature risk of fire, keep electrical cords, drapery, furnishings and other Combustibles At least 3 feet (0.9m) from front of heater and away from side and rear of heater.

HEATSTRIP[®]



Innovative, High Performance Electric Heating Technology

Features & Benefits

High Output radiant heat

HEATSTRIP[®] *Intense* with remote & app control electric radiant heaters produce radiant heat that travels through the air directly to people and surfaces below – similar to the heat rays emitted by the Sun. Radiant heating is the only viable option for outdoor or tough indoor sites.

Maximum heat performance – multiple applications

The high temperature output of the HEATSTRIP[®] *Intense* with remote & app control (THBBA-UL) is perfect for exposed outdoor sites, high ceilings and hard-to-heat indoor and outdoor applications.

Suitable for permanent outdoor mounting, no protection needed.

For outdoor applications, the HEATSTRIP[®] *Intense with remote & app control* (THBBA-UL) is suitable for both permanently exposed (eg. courtyards and patios) and undercover installations - does not need to be fully protected from the elements.

Corrosion protection

Built from corrosion resistant alloy, it is suitable for use in most applications, including difficult corrosive environments such as coastal areas.

Multi-Purpose Mounting Options

The HEATSTRIP[®] *Intense with remote & app control* is supplied with flexible mounting options. The standard bracket will allow both ceiling and wall mounting, at various angles, as well as suspension by chains/wires and metal rods.

Element

Carbon filament infra-red heating element provides high performance instant heat.

Warranty

2-year residential and 1-year commercial warranty.

Material & Design

Anodised alloy casing and end caps with a powder coat hexagon grille.



HEATSTRIP®



Specifications - Australia

MODEL	VOLTAGE (V)	POWER (Watts)	CURRENT (Amps)	DIMENSIONS (mm / in)	WEIGHT (kg / lb)	CONNECTION	HEATING AREA (m ² x ft ²)
THB2200BA-UL	240	2200	9.2	900 x 122 x 90mm 35.4" x 4.8" x 3.5"	6kg 13lb	Gang Box	5-9m ² 54-97ft ²
THB3200BA-UL	240	3200	13.3	1040 x 122 x 90mm 41" x 4.8" x 3.5"	7kg 15lb	Gang Box	8-13m ² 86-40ft ²

MODEL							
HEATER TYPE	High intensity electric radiant, infra-red overheat heater with carbon filament element.						
OUTPUT	2200 watts or 3200 watts						
POWER	240-240 Volts Nominal at 50—60 Hertz, Single Phase						
CONNECTION	Gang box						
APPROVALS							
MOUNTING HEIGHT	<table border="0"> <tr> <td>MINIMUM</td> <td>7ft (2.1m)</td> </tr> <tr> <td>RECOMMENDED</td> <td>8ft—9ft (2.3m - 2.5m)</td> </tr> <tr> <td>MAXIMUM</td> <td>2.8m / 9ft Outdoors and 3m/10ft Indoors (For higher ceiling heights, units can be lowered using optional brackets kits)</td> </tr> </table>	MINIMUM	7ft (2.1m)	RECOMMENDED	8ft—9ft (2.3m - 2.5m)	MAXIMUM	2.8m / 9ft Outdoors and 3m/10ft Indoors (For higher ceiling heights, units can be lowered using optional brackets kits)
MINIMUM	7ft (2.1m)						
RECOMMENDED	8ft—9ft (2.3m - 2.5m)						
MAXIMUM	2.8m / 9ft Outdoors and 3m/10ft Indoors (For higher ceiling heights, units can be lowered using optional brackets kits)						
MOUNTING OPTIONS	Suitable for ceiling, wall, and beam mounting as well as suspension by chains & wires using standard brackets. Optional mounting accessories include extension mount poles and flush ceiling mount kit.						
PROTECTION RATING	IPX5 Protection from water ingress from all directions						
MATERIALS OF CONSTRUCTION	Anodised alloy casing and end caps with powder coat grille (THB2200BA-UL & THB3200BA-UL)						

THB2200BA-UL

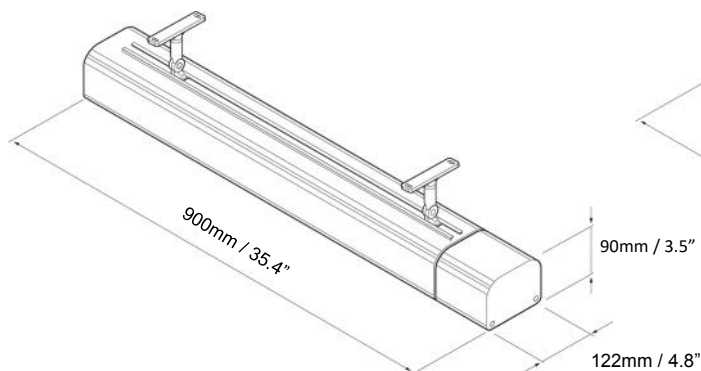

THB3200BA-UL

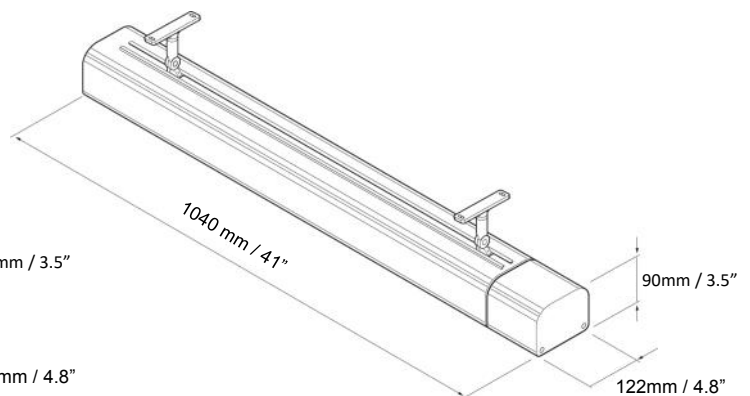



Spot heating principle

In most outdoor or difficult-to-heat indoor applications, there are 2 methods when looking at the size and quantity of heaters required.

Option 1 is to comfort heat the entire area based on the total dimensions of the space, regardless of whether the entire area is being fully occupied or not.

Option 2 is to spot heat the high use areas, such as over outdoor tables, BBQ's, lounges, assembly lines or indoor workstations.

Often it is more practical and efficient to spot heat these areas. Spot heating will help to reduce the initial capital cost, as well as the on-going running costs. Spot heating will allow the area to be "zoned", meaning heating only the areas that are being used, such as tables in a restaurant or outdoor alfresco area.

The top diagram shows how HEATSTRIP® *Intense* with remote & app control is recommended to be used directly over a table, while the bottom diagram indicates how to spot heat a large area.

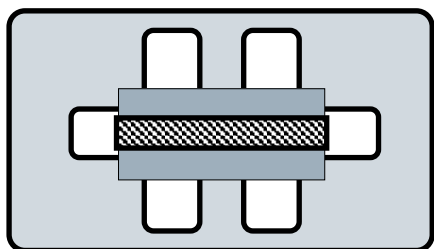

THB2200BA-UL
Over Table

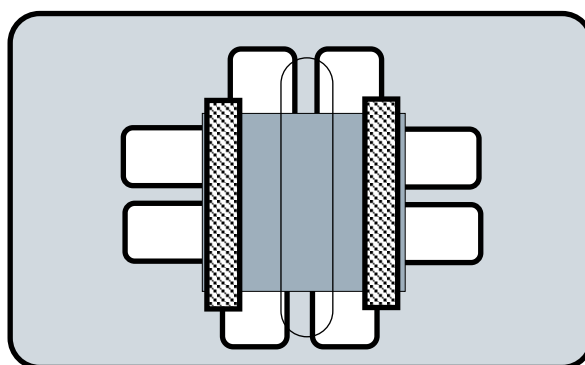

THB3200BA-UL
Over Table

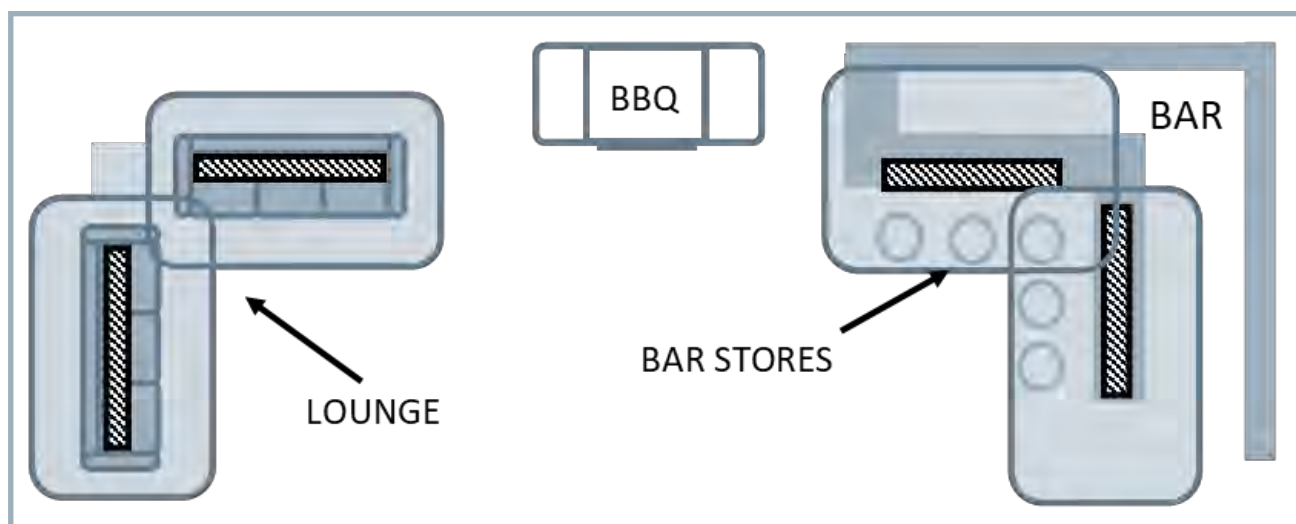



Selection guide

General recommendations for **HEATSTRIP® Intense with Remote and App control:**

- Ideal mounting height: 2.2m/7ft to 2.5m/8ft, and the maximum is 2.8m/9ft. Minimum is 2.1m/7ft.
- Ideal mounting location: ceiling mounted, directly above area to be heated (e.g. above a table)

The below table outlines the coverage HEATSTRIP® *Intense with remote and app* model (in m² & ft), based on 3 different scenarios.

For example, in an outdoor area that is protected from prevailing winds by walls, café blinds etc, (e.g. outdoor enclosed)

This data is based on direct overhead ceiling mounting. If the heaters are wall mounted, the radiant footprint will be reduced. Above data is based on direct overhead ceiling mounting. If the heaters are wall mounted, the radiant footprint may be reduced.

The below diagrams show the approximate heating area for each model, based on both an indoor protected,

MODEL	INDOOR PROTECTED (m ² / ft)	OUTDOOR ENCLOSED (m ² / ft)	OUTDOOR EXPOSED (m ² / ft)
THB2200BA	14m / 45ft	9m / 29ft	5m / 16ft
THB3200BA	21m / 69ft	13m / 42ft	8m / 26ft





Table Layout

General recommendations for **HEATSTRIP® Intense with Remote & App Control:**

- Ideal mounting height: 2.2m-2.5m / 7ft - 8ft, and the maximum is 2.8m/9ft. Minimum is 2.1m/7ft.
- Ideal mounting location: ceiling mounted, directly above area to be heated (e.g. above a table)

For the majority of outdoor applications, the most effective method is to spot heat a table or similar area. The diagrams below provides an easy selection guide for the approximate model and quantity of heaters required to heat common residential table settings

Selection are based on HEATSTRIP *Intense* being mounted at 2.4m/7.8ft from the floor in a fully enclosed undercover outdoor area.

Above data is based on direct overhead ceiling mounting. If the heaters are wall mounted, the radiant footprint may be reduced.

The below diagrams show the approximate heating area for each model, based on both an indoor protected, outdoor enclosed and outdoor exposed location.

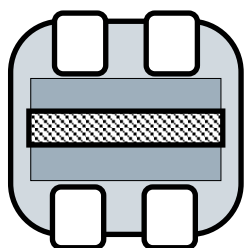

THB2200BA-UL

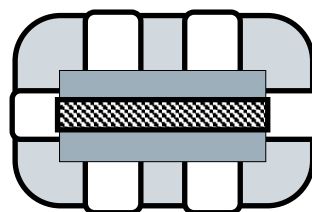

2x THB3200BA-UL

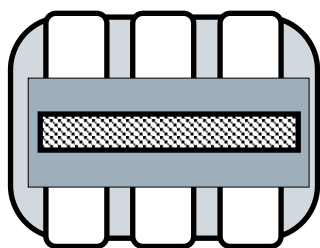

THB3200BA-UL

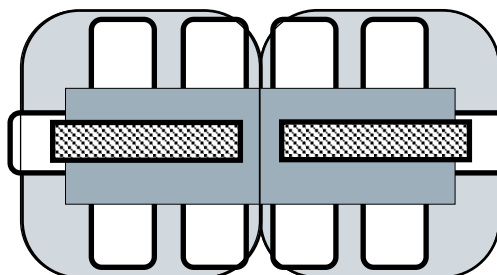

2x THB2200BA-UL

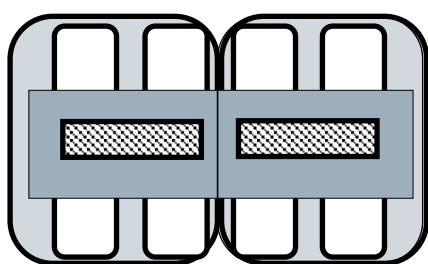

2x THB2200BA-UL

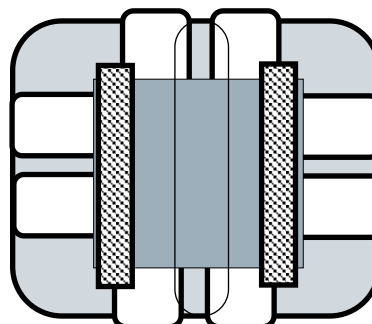

2x THB3200BA-UL

HEATSTRIP[®]



Installation Requirements

The ideal mounting position for the HEATSTRIP[®] *Intense* with remote & app control is on the ceiling, directly above the area to be heated. If this is not possible, HEATSTRIP[®] *Intense with remote & app control* can be mounted on a wall and angled downwards. In this situation, ensure the mounting height is in the range of 2.1m to 2.5m / 7-8ft.

For mounting heights more than 2.8m/9ft outdoors, we recommend the use of the optional accessories to reduce the height of the heater to 2.3m—2.5m/8-9ft. This will increase the effectiveness of your HEATSTRIP[®]. Refer to the Mounting Accessory section for more information.

Electrical connections/GPO's should not be located at the back of the heater. They should be located outside the physical footprint of the units to minimize heat build-up behind the units.

The HEATSTRIP[®] *Intense* is not suitable for mounting on an incline, along the length.

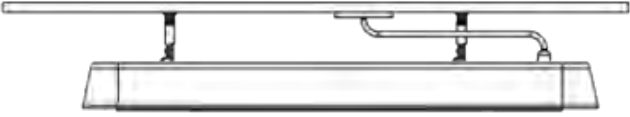
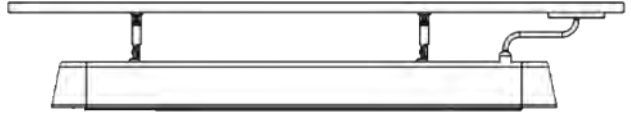
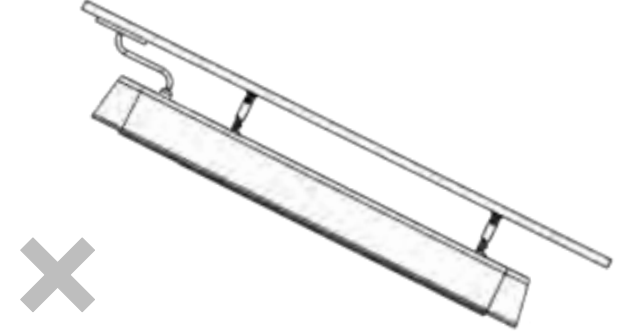
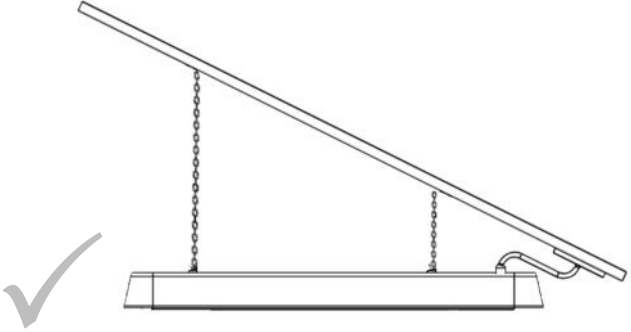
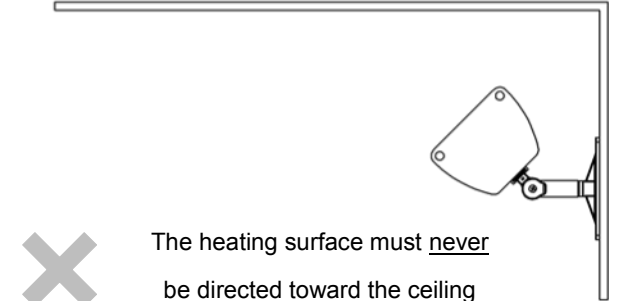
Incorrect Installation	Correct Installation
 ✘	 ✔
 ✘	 ✔
 ✘ The heating surface must <u>never</u> be directed toward the ceiling	

HEATSTRIP[®]



Installation location — the below diagrams confirm the minimum recommended clearances.

Angled Wall Installation

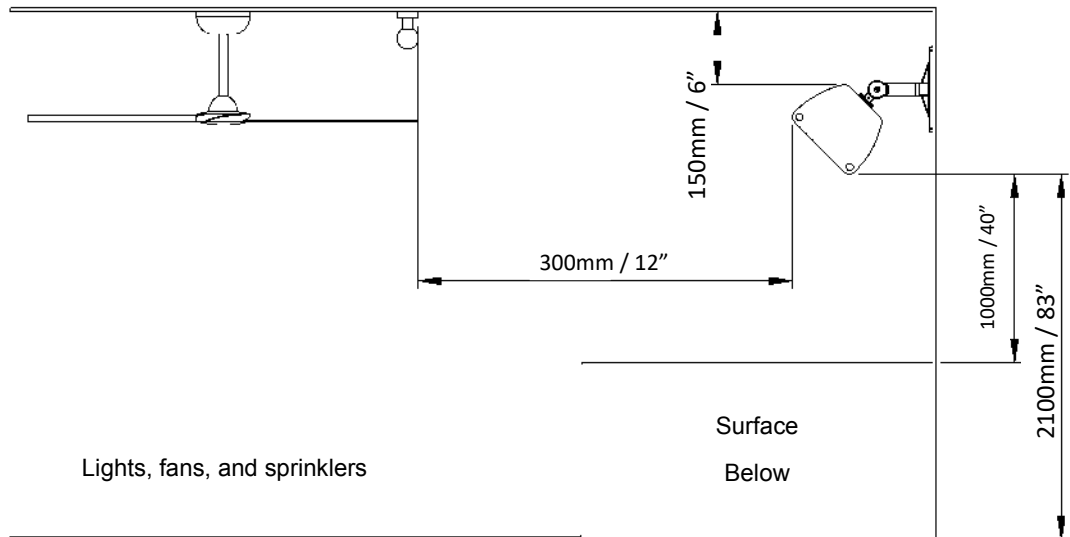

Ceiling Installation

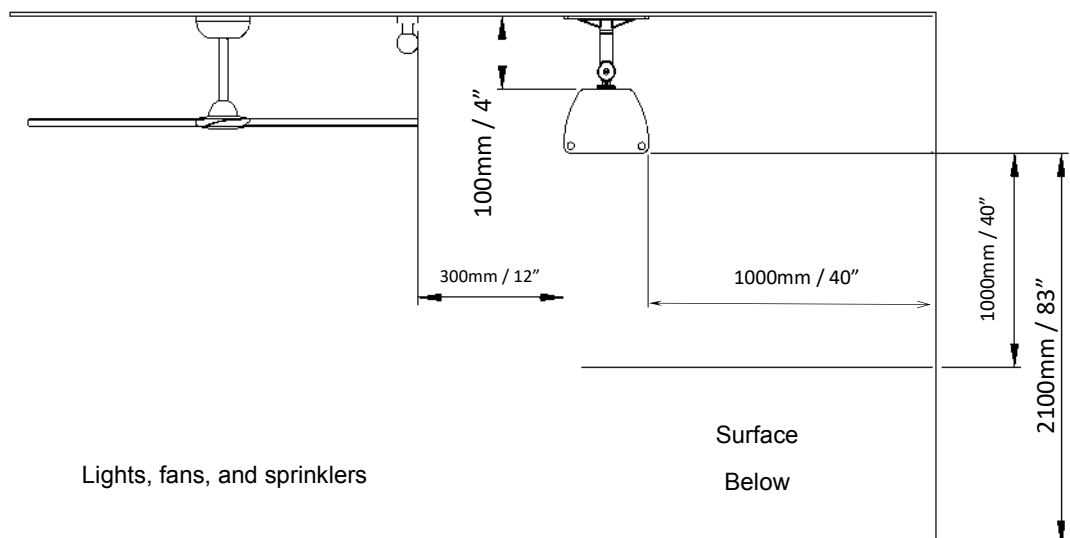

HEATSTRIP®

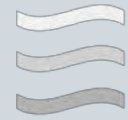

Mounting options

The installation of HEATSTRIP® *Intense with remote & app (THB-BA-UL)* is simple and easy with the standard mounting brackets supplied. For other more challenging locations there are a range of mounting options available - refer to below diagrams.

The HEATSTRIP® *Intense with remote & app control* can be mounted directly to the ceiling, flush mounted into the ceiling, angled downwards on a wall, suspended on chains, poles or attached to beams and rafters. Refer to the following pages for more detailed information on each mounting option.

CEILING

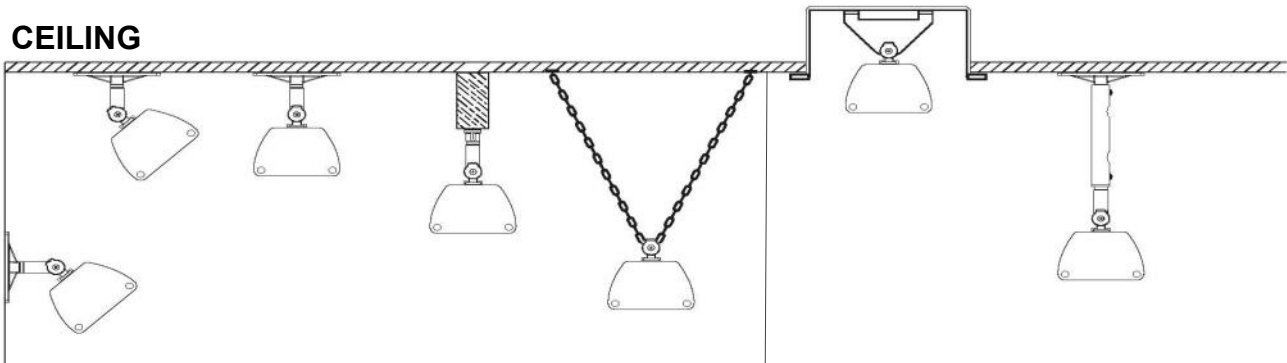

Installation options with standard bracket
(*Chain not included)

Optional Mounting Accessories

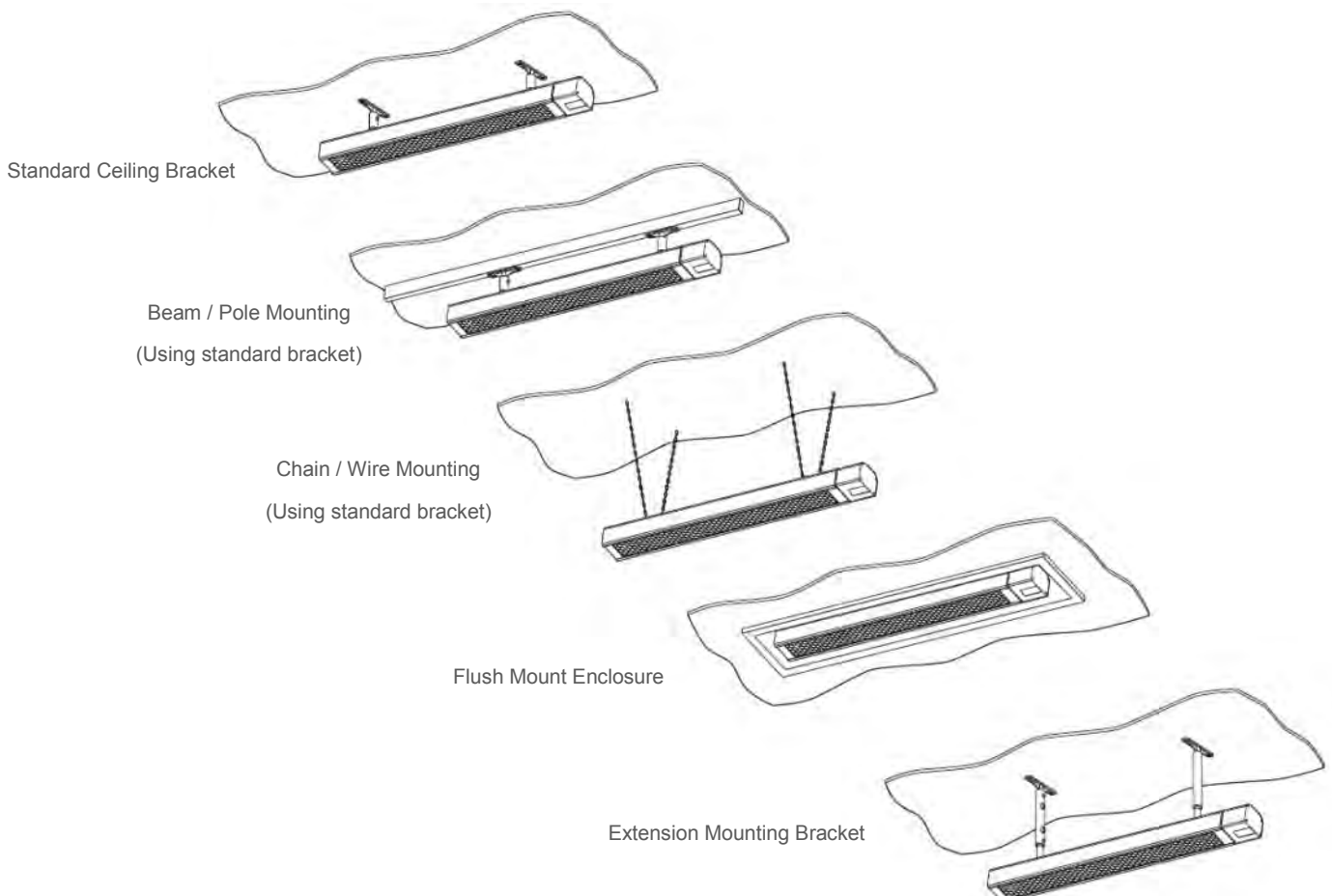

HEATSTRIP®



Standard mounting brackets

The HEATSTRIP® *Intense with remote & app control* comes with a pair of standard mounting brackets. These adjustable brackets allow direct ceiling or wall mount, and come with pre-set angle options of parallel, 22.5° and 45°.

The flexible standard mounting bracket can be turned 90 degrees to mount onto a beam, it can also be used to suspend with chains.

The brackets need to be mounted onto a secure frame or wall with a minimum distance between the two brackets. The minimum distance ("B") for each model is listed on the next page. All dimensions shown below are in (").

When completing the installation, ensure all screws are tight and unit is secure.

Note: When suspension mounting, chains are not included.

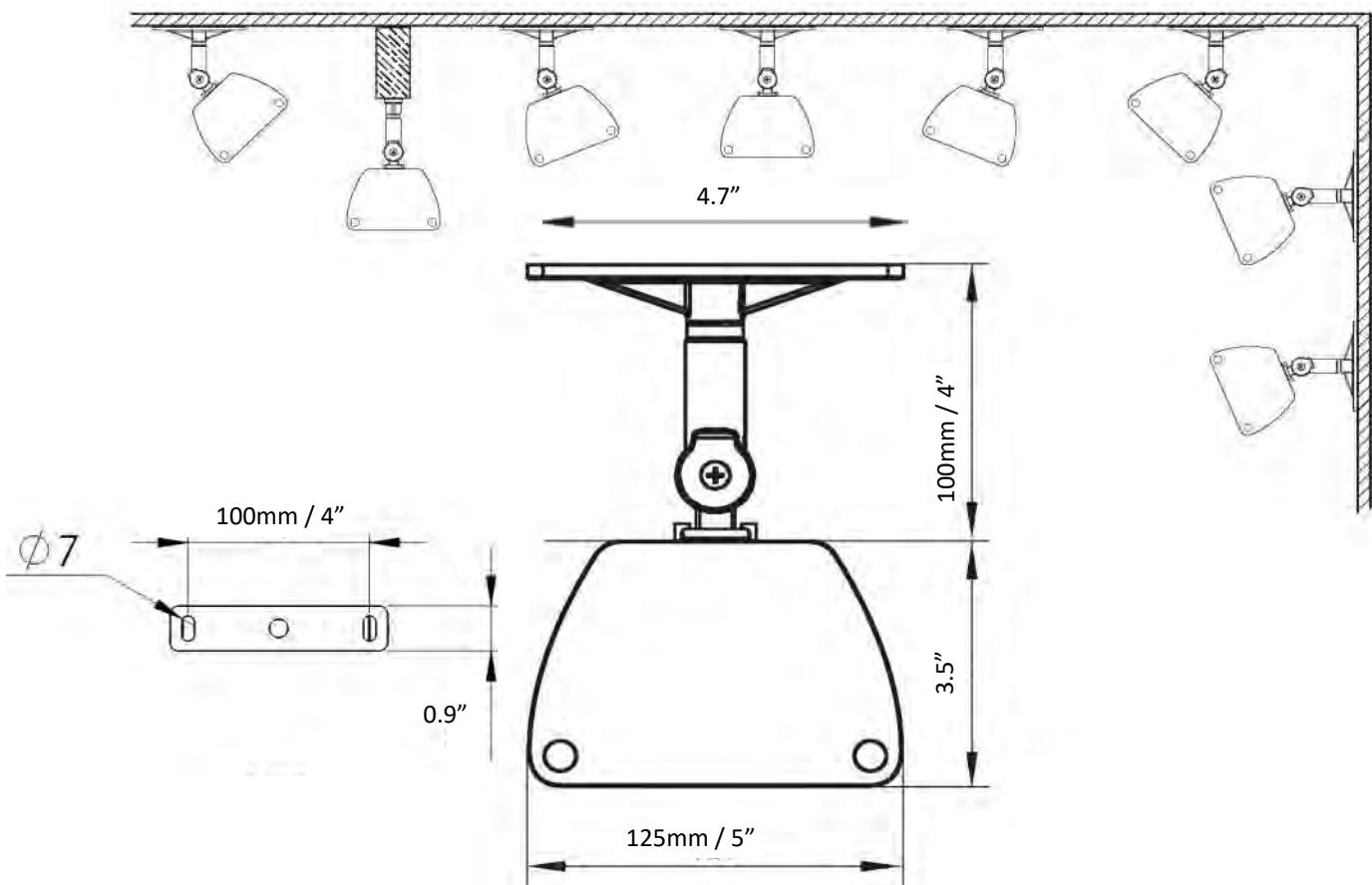

Standard Mounting Bracket

PART No	PACKAGED DIMENSIONS (mm/inches)	WEIGHT (kg/lbs)	MATERIALS	COLOUR
ZBRAK-132B	125 x 100 x 40mm 5" x 4" x 1.5"	0.2 0.44lbs	ANODISED	BLACK

HEATSTRIP[®]



MOUNTING

Fix the two mounting brackets to the ceiling or wall in the desired location (refer minimum bracket centre chart). Make sure the method of fixing (bolts or screws) will be more than strong enough to support the weight of the heater, allowing for strong winds and other conditions.

- Slide the 2 locking brackets into the groove on the back of the heater. Make sure the pins on the locking bracket are facing the matching holes in the top mounting bracket.
- Lift heater into position and secure the 2 locking brackets to the mounting brackets using the screws provided. Make sure the 2 pins on the locking bracket engage with the matching holes in the mounting bracket. The pins will allow for both horizontal or angle mounting as required
- Tighten all screws and tighten the round nut at the top of the bracket, so it locks onto the top part of the mounting bracket.

NOTE: The standard bracket allows for normal or angle mounting of the heater and is suitable for ceiling or wall mounting.

MODEL	"B" MINIMUM DISTANCE (inches)
THB2200BA-UL	14"
THB3200BA-UL	28"

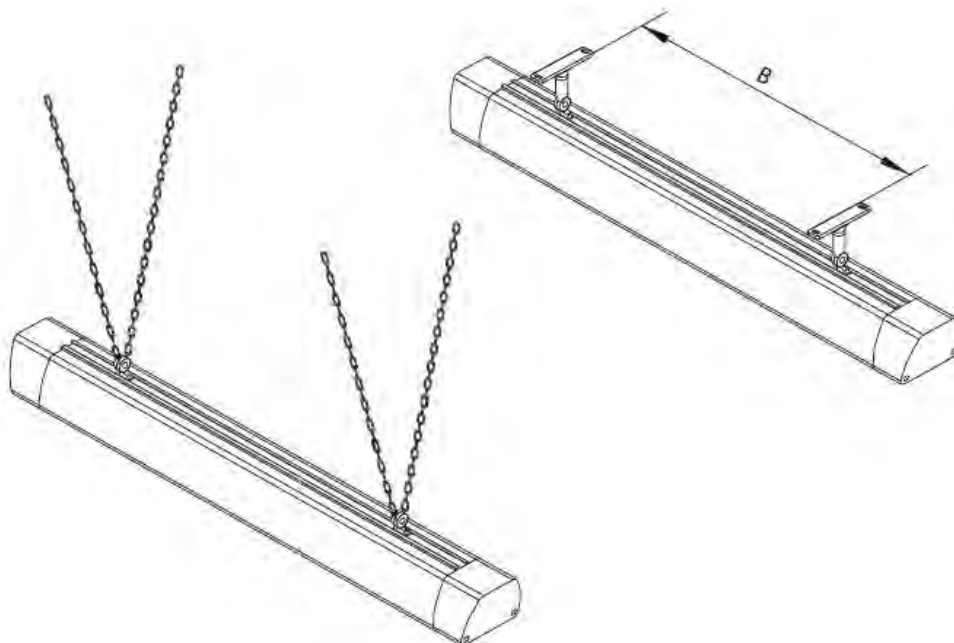

HEATSTRIP®



Extension Mount Bracket

The Extension Mount bracket allows HEATSTRIP® *Intense* units to be lowered from high ceilings using rigid connections. The standard length options as part of the kit are 150mm (5.9"), 300mm (11.8"), 600mm (23.6"), 900mm (35.4") and 1200mm (47.2").

The extension mount bracket utilises components from the standard bracket kit which is supplied with each heater.

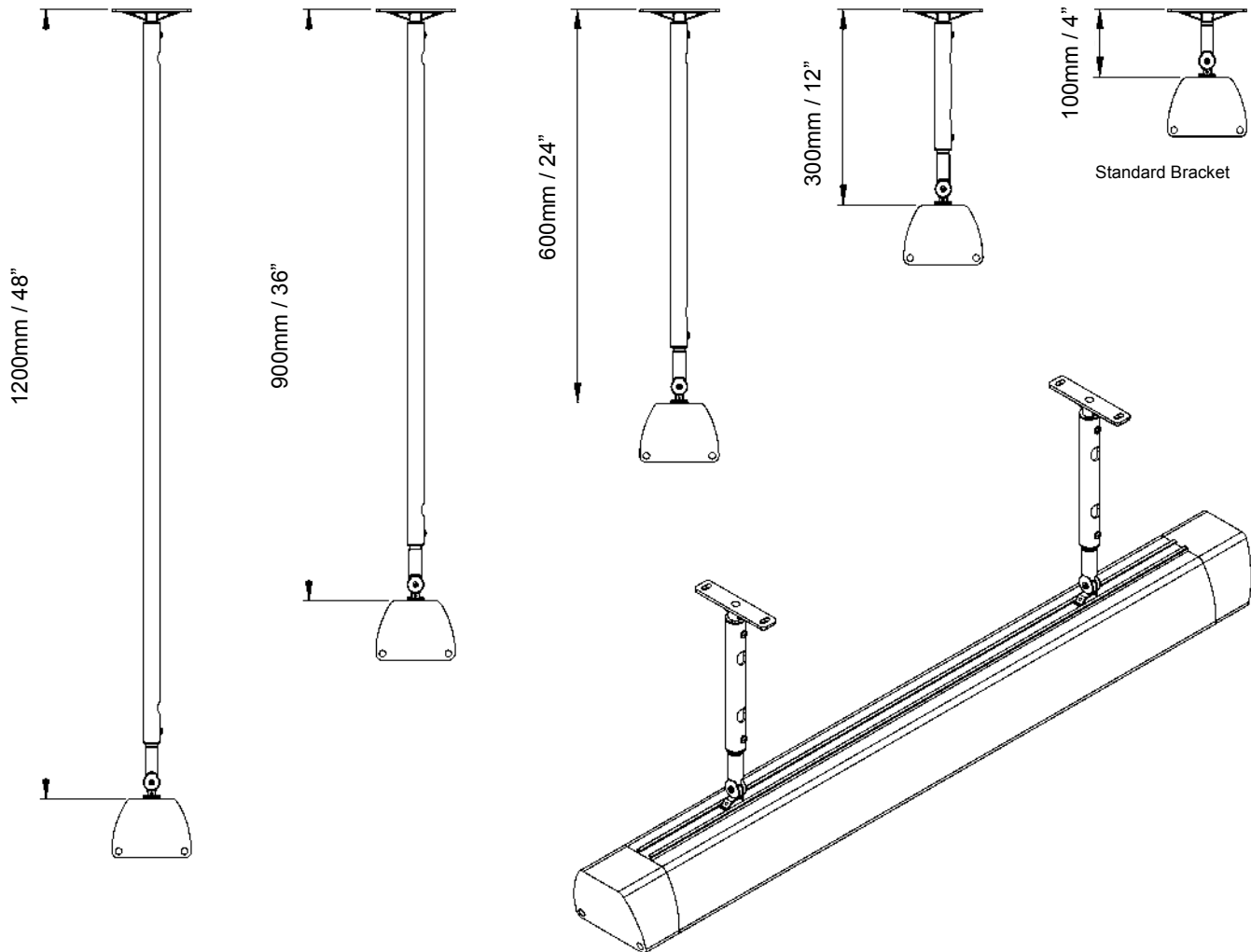

PART No. Suitable for THB2200BA-UL / THB3200BA-UL	PACKAGED DIMENSIONS (mm/ ft)	WEIGHT (lbs)	MATERIALS	NOTES
THYAC - 047	12" x 6" x 2" (300 x 150 x 50mm)	5 lbs (2 kgs)	ALLOY	Kit includes 2 x 12" (300mm) extension pole
THYAC - 048	24" x 6" x 2" (600 x 150 x 50mm)	5 lbs (2 kgs)	ALLOY	Kit includes 2 x 24" (600mm) extension pole
THYAC - 049	36" x 6" x 2" (900 x 150 x 50mm)	6 lbs (2.5 kgs)	ALLOY	Kit includes 2 x 36" (900mm) extension pole
THYAC - 050	48" x 6" x 2" (1200 x 150 x 50mm)	7 lbs (3 kgs)	ALLOY	Kit includes 2 x 48" (1200mm) extension pole

HEATSTRIP®



Flush mount enclosure

The Flush Mount Enclosure is an ideal way to neatly install the HEATSTRIP® into a ceiling. They are available for the HEATSTRIP® *Intense with Remote & App* model, and are supplied as a one-piece unit suitable for mounting individual heaters. Flush mounting can be used with plaster or timber lined ceiling materials.

An ideal mounting height is 2.1m - 2.5m / 7ft to 8ft , with a maximum ceiling height of 2.7m / 7ft in an outdoor enclosed environment. Maximum mounting heights should be strictly followed, otherwise the performance of the units may be reduced.

A minimum clearance of 200mm behind the enclosure must be provided.

The enclosure for the THB2200BA-UL & THB3200BA-UL is manufactured from black powder coated steel, with a black fascia.

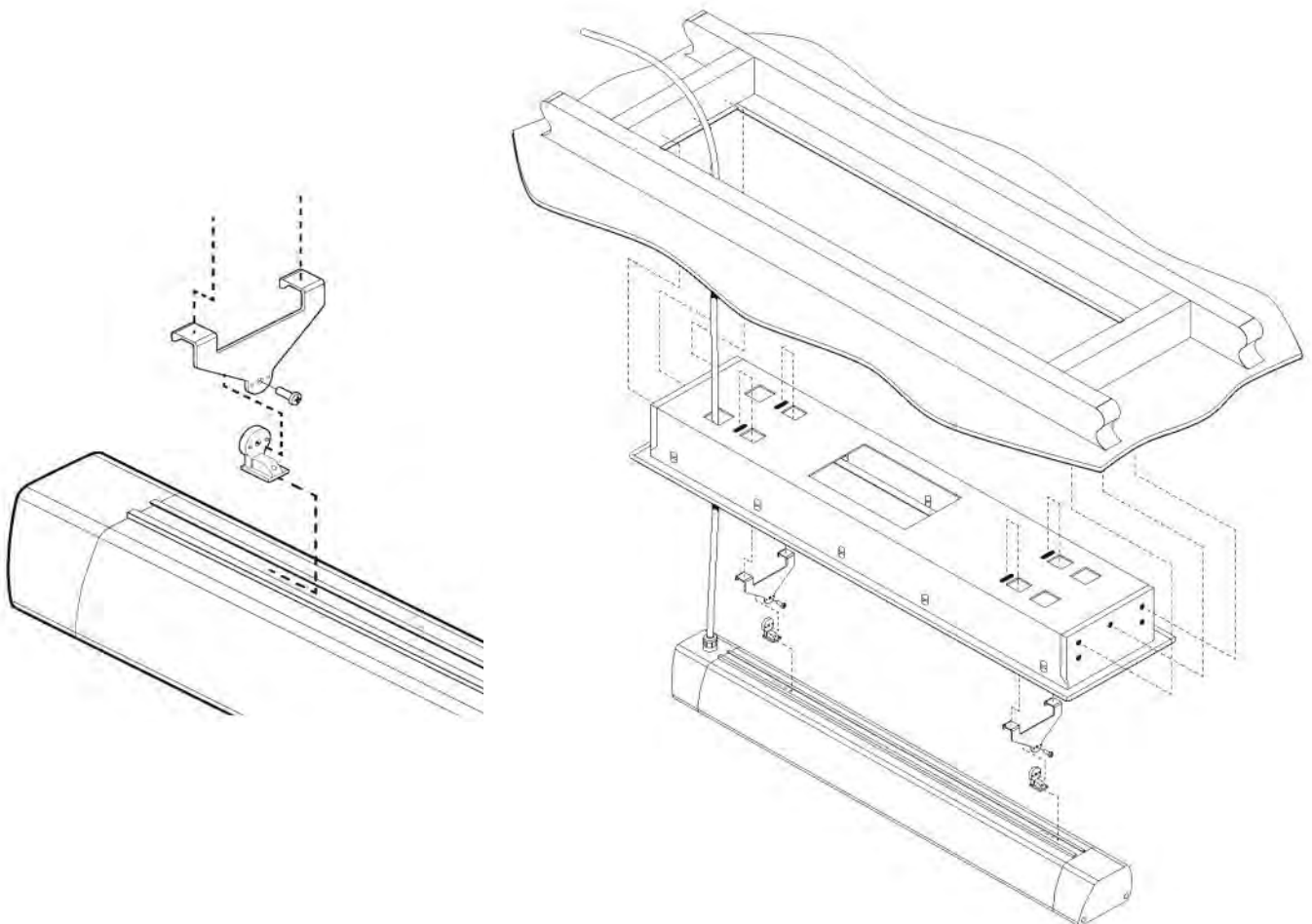

SUITABLE FOR MODEL	PART No	HOLE CUTOUT DIMENSIONS (mm/")	OVERALL DIMENSIONS (mm/")	WEIGHT (kg/lbs)
THB2200BA	THBAC-001	1015(L) x 205(W)mm 40" (L) x 8" (W)	1070(L) x 258(W) x 201(D)mm 42" (L) x 10" (W) x 8" (D)	4kg / 9lbs
THB3200BA	THYAC-051	1152(L) x 205(W)mm 45" (L) x 8" (W)	1208(L) x 258(W) x 201(D)mm 48" (L) x 10" (W) x 8" (D)	5kg / 11lbs

HEATSTRIP[®]



Remote Control Operation

Receiver

- Receiver is located on the heater.

Signal Transmitter

- To use the remote controller, aim the transmitter to the heater. A line of sight transmission is required for the unit to function.
- The controller does not have a protection rating. The controller must be kept away from wet applications.
- The remote will function at distances of over 8m when used in a straight line. This distance reduces when used at an angle.

Temperature Control Button

- Press ON-H temperature will be adjusted to HIGH.
- Press ON-L temperature will be adjusted to LOW.

OFF Button

- Press this button once to turn OFF operation.

Battery

- AAA Battery required for operation.

Automated Countdown Timer

- Press 1H to begin 1 hour automatic shutdown.
- Press 2H to begin 2 hour automatic shutdown.
- Press 4H to begin 4 hour automatic shutdown.



REMOTE FUNCTIONS

ON-H	Temperature High
ON-L	Temperature Low
OFF	Unit Off
1H	1H Automatic Timer
2H	2H Automatic Timer
4H	4H Automatic Timer

HEATSTRIP[®]



THB-BA Setup Instructions

1

Visit the Apple App store or Google Play and download TuyaSmart App

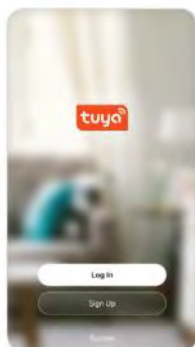

2

Register and login into TuyaSmart App. (Make sure Wi-Fi is enabled)

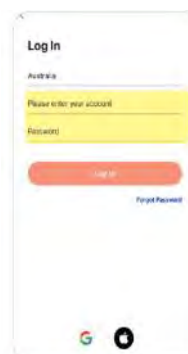

3

Connect the HEATSTRIP Heater to Power. (Either Plug-In or Hardwired)

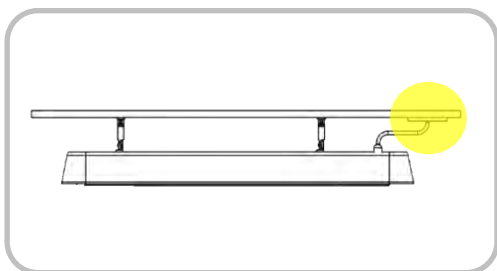

4

Once the power is switched on, hold the + button on the remote until the LED screen is blinking CC.



5

Open the App and select "Add Device"

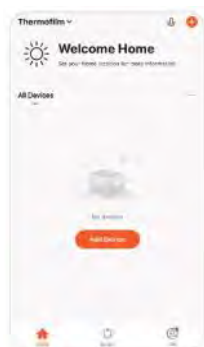

6

Select Device Type "Small Appliances".



7

Select "Heater"



8

Select "Next" (Wi-Fi must be connected).



HEATSTRIP[®]



THB-BA Setup Instructions

9

Confirm the 3 indicator is blinking rapidly on the heater and select “Next” (If the LED lights are not blinking on the heater, you will need to hold down the 2H button on the remote until the 3 indicators are blinking).



10

Once the pairing cycle has been completed, the App and HEATSTRIP Heater should be paired together.

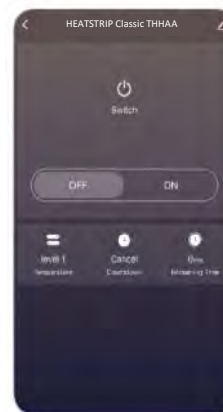

Pairing with Google Assistant

1. Download the Google Home app on the app store or Google play
2. Pair the Google device to the Google Home App
3. Once paired, click on the Tuya Smart App
4. Select “Me”
5. Select “Google Assistant”
6. Select “Link with Google Assistant”
7. Select “Agree and link”
8. Choose device “Select HEATSTRIP Intense with Remote & App
9. Pairing completed

HEATSTRIP[®]



SYMPTOM	REASON	CHECK END USER	CHECK TECHNICIAN	FIX
Freight damage	Damaged during transport	Inspect units for damage	Take photos of packaging and unit and return to factory	Return to factory for repair/ replacement
Missing brackets	Parts missing from box			Contact factory for replacement brackets
Not heating	No power to unit or unit has short circuited	Check that there is power to the unit	Check the resistance across the active and neutral terminals	Return to factory for repair/ replacement
	Cable is damaged	Inspect cable for cuts, scratches, nicks etc.		Return to factory for repair/ replacement
Not hot enough	Not enough power to the unit		Electrician to check there is sufficient voltage and current to the unit	Wire correctly with correct current
	Did not wait for the unit to warm up	Wait 15 minutes for the temperature to reach its maximum		Normal Operation
	Multiple units are connected in series not in parallel and not getting enough power		Check the circuit that each one has been wired separately with the correct voltage and current	Wire correctly with correct current
Take too long to heat up	Insufficient power to the unit		Check the voltage and current to the units	Increase power
Discolouration/face of the unit is browning	Heater is over heating		Check that the power supplied matches the rated power on the compliance plate	Replace heater with correctly rated heater
	Environmental factors			Clean heater according to the Cleaning and Maintenance instructions
	This is normal wear for the heater.			Paint the face of the unit using a 600 degree high temperate engine black paint. Available from automotive stores. We can not send these out as aerosols can not be sent in the post

HEATSTRIP[®]



Safety

HEATSTRIP[®] Enhance with Remote and App control (THGBA-UL) has an IP rating of X5. This means it is safe for water ingress from all directions. The HEATSTRIP[®] can be safely hosed down.

HEATSTRIP[®] has undergone extensive testing both in laboratory conditions, in field trials in Australia and overseas. It is this testing that gives the purchaser the confidence of a high quality product.

Independent laboratory testing has confirmed Thermofilm's full compliance with Australian and other International Standards including CE, AS/ANZ, UL/CSA

The heater comes in 2400W and 3200W versions. In all events the fixed wiring must be installed by a licensed electrician in accordance with the relevant wiring regulations.

In operation, this heater is VERY HOT— do not touch any part of the heater while it is turned on. Do not touch any part until 30 minutes after it is turned off.

This appliance is not intended for use by persons (including children) with reduced physical, sensory or intellectual capabilities, or lack of experience and knowledge, unless they have been given supervision or instruction concerning use of the appliance by a person responsible for their safety. Children should be supervised to ensure they do not play with the appliance.

Do not allow any cables, furnishings, flammable materials or other items come in contact with any surface of the heater.

If installed in wet areas, the heater switches or controls must be located so that they cannot be touched by persons in the bath or shower.

The heater needs to be installed as per the installation instructions paying special attention to the minimum clearances. The heater needs to be mounted on a rigid bracket or fixing.

The heater must not be mounted immediately below or in front of a socket outlet.

In case of a heater fault or damaged supply lead, the appliance should be returned to the point of purchase for return to Thermofilm for repair.

Maintenance

The HEATSTRIP[®] Enhance with Remote and App control (THGBA-UL) is made from durable materials, however regular care and maintenance of your heater will help prolong the life of the heater.

It is recommended that you hose down the heater and with a soft cloth gently wipe the surfaces of the heater with a mild detergent to remove the built up contaminants from the environment. Then rinse all detergent off the heater.

All chemicals in the atmosphere including cigarette smoke, pollution etc. will tarnish the surface of the heater. In this case, additional cleaning and maintenance may be required. Carrying out the cleaning process at least every three months will reduce the amount of build up and keep the Heatstrip in good condition. If the heater is in a corrosive environment eg. salt spray, we recommend that you clean your heater with a light spray of fresh water every week. After cleaning, turn the heater on for 20 minutes to dry any water residue and prevent water staining.

Before cleaning or inspection activity, the heater must be switched off and cooled down completely.

Do not use any abrasive materials or products to clean the heater, this includes solvents, citrus based cleaners or other harsh cleaning products.

When handling the heater, ensure that your hands are clean or that you use clean gloves as grease or dirt can mark the surface of the heater.

Do not use high pressure water to clean heaters, light water spray only.

HEATSTRIP[®]



SYMPTOM	REASON	CHECK END USER	CHECK TECHNICIAN	FIX
Freight damage	Damaged during transport	Inspect units for damage	Take photos of packaging and unit and return to factory	Return to factory for repair/ replacement
Missing brackets	Parts missing from box			Contact factory for replacement brackets
Not heating	No power to unit or unit has short circuited	Check that there is power to the unit	Check the resistance across the active and neutral terminals	Return to factory for repair/ replacement
	Cable is damaged	Inspect cable for cuts, scratches, nicks etc.		Return to factory for repair/ replacement
Not hot enough	Not enough power to the unit		Electrician to check there is sufficient voltage and current to the unit	Wire correctly with correct current
	Did not wait for the unit to warm up	Wait 15 minutes for the temperature to reach its maximum		Normal Operation
	Multiple units are connected in series not in parallel and not getting enough power		Check the circuit that each one has been wired separately with the correct voltage and current	Wire correctly with correct current
Take too long to heat up	Insufficient power to the unit		Check the voltage and current to the units	Increase power
Discolouration/face of the unit is browning	Heater is over heating		Check that the power supplied matches the rated power on the compliance plate	Replace heater with correctly rated heater
	Environmental factors			Clean heater according to the Cleaning and Maintenance instructions
	This is normal wear for the heater.			Paint the face of the unit using a 600 degree high temperate engine black paint. Available from automotive stores. We can not send these out as aerosols can not be sent in the post

HEATSTRIP[®]



Warranty Terms & Conditions

The below Warranty Terms and Conditions apply for **International Customers**.

Thermofilm warrants to the original owner that HEATSTRIP[®] Enhance with Remote and App control products will be free from defects in materials and workmanship for a period of 12 months from the date of purchase in accordance with the following warranty terms and conditions.

Provision of this warranty is subject to:

- The HEATSTRIP[®] product must be installed in accordance with the Installation Instructions and relevant electrical standards and codes.
- The HEATSTRIP[®] product must be maintained and cleaned according to instructions detailed in the Installation Manual.
- There is no warranty expressed or implied with regard to capacity requirements. The selection of the unit or units depends entirely upon the system design and capacities as determined by the purchaser.
- The customer has not repaired, opened or altered the product in any unauthorised manner.
- This warranty excludes damage to the product or components arising from circumstances outside the control of Thermofilm, including, but not limited to, where the product is not used for intended purpose; where the product has been rectified in any way; incorrect installation; incorrect power supply; damaged caused during delivery; misapplication, misuse, abuse, vandalism, lack of maintenance or accident.
- Thermofilm's obligations under this warranty are limited to repair or replacement at Thermofilm's factory of any components of the product which Thermofilm identifies to its satisfaction to be defective.
- Transportation charges involved in return of the product to the Thermofilm factory (or any other location authorised in writing by Thermofilm) is the sole responsibility of the customer.
- All products are inspected and tested before despatch and are at the risk of the purchaser after the shipment from the Thermofilm factory, if not delivered by Thermofilm to destination.
- Discolouration of the surface may occur after a period of time, this does not constitute a warrantable event.
- Twisting and bending of the heaters may occur, this does not constitute a warrantable event.
- No products or components will be supplied in advance of an examination of the faulty product or components by Thermofilm or an authorized representative of Thermofilm.
- Thermofilm does not participate in any site related costs or labour expenses incidental to replacement of parts, repairing, removing, installing, servicing, transportation or handling of parts to complete products, and assumes no liability on parts repaired or replaced without written authorisation. Thermofilm shall not be liable for any default or delay in performance of its warranty obligations caused by any circumstances beyond its control, including, but not limited to, judicial or government restrictions, strikes, fires, floods, abnormal weather conditions, delayed supply of components.

Should products be determined as damaged on arrival, immediately notify the transport company of the condition and have them noted on the freight documents. If damage is discovered after unpacking, demand immediate inspection by the transportation company and insist that a record of the damage is made on the freight documentation.

The customer warrants using the product in accordance with:

- Any instructions provided to it by Thermofilm from time to time.
- All government and local regulations, including but not limited to all relevant electrical, environmental laws and regulations governing the installation, storage, use, handling and maintenance of the goods.
- All necessary and appropriate precautions and safety measures relating to the installation, storage, use, handling and maintenance of goods.

All warranty requests for repairs or replacements must be accompanied by a complete "Warranty Claim Form" available from Thermofilm, together with proof of purchase (and where possible, photos of the installation) and the heater returned to the place of purchase.

In the event of a warranty claim, the goods need to be returned to the distributor/retailer for repair/replacement.

AMD Direct Inc.

14520 Delta Lane, Ste 105
Huntington Beach, CA 92647

Phone: 800-966-8126

Email: Heatstrip@amddirect.com