

HEATSTRIP[®]

Max DC— Commercial (X-THX4000DC &
X-THX6000DC)



HEATSTRIP[®] Max DC (X-THX4000DC & X-THX6000DC)

www.heatstrip.com

US & CANADA

HEATSTRIP[®]



Safety

HEATSTRIP[®] Max DC has an IP rating of X5. This means it is safe for water ingress from all directions. The HEATSTRIP[®] can be safely hosed down. HEATSTRIP[®] has undergone extensive testing both in laboratory conditions; in Thermofilm's manufacturing facility in Melbourne and field trials in Australia and overseas. It has been this testing that gives the purchaser the confidence of a high quality product.

Independent laboratory testing has confirmed Thermofilm's full compliance with Australian and other International Standards. This includes CE, AS/ANZ, UL/CSE

The heater comes hardwired (6000W & 4000W) versions. In both cases the fixed wiring must be installed by a licensed electrician in accordance with the relevant wiring regulations.

HEATSTRIP[®] is Class 1 equipment and must be earthed.

In operation, this heater is VERY HOT— do not touch any part of the heater while it is turned on. Do not touch any part until 30 minutes after it is turned off.

This appliance is not intended for use by persons (including children) with reduced physical, sensory or intellectual capabilities, or lack of experience and knowledge, unless they have been given supervision or instruction concerning use of the appliance by a person responsible for their safety. Children should be supervised to ensure they do not play with the appliance.

Do not allow any cables, furnishings, flammable materials or other items come in contact with any surface of the heater.

If installed in wet areas, the heater switches or controls must be located so that they cannot be touched by persons in the bath or shower.

The heater needs to be installed as per the installation instructions paying special attention to the minimum clearances. The heater needs to be mounted on a rigid bracket or fixing.

The heater must not be mounted immediately below or in front of a socket outlet.

In case of a heater fault or damaged supply lead, the appliance should be returned to the point of purchase for return to Thermofilm for repair.

Maintenance

The HEATSTRIP[®] is made from durable materials, however regular care and maintenance of your heater will help prolong the life of the heater.

It is recommended that you hose down the heater and with a soft cloth gently wipe the surfaces of the heater with a mild detergent to remove the built up contaminants from the environment. Then rinse all detergent off the heater. All chemicals in the atmosphere including cigarette smoke, pollution etc. will tarnish the surface of the heater. In this case, additional cleaning and maintenance may be required. The cleaning process at least every three months will reduce the amount of build up and keep it looking as best it can. If the heater is in a corrosive environment eg. salt spray, we recommend that you clean your heater with a light spray of fresh water every week. After cleaning, turn the heater on for 20 minutes to dry any water residue and prevent water staining. Before cleaning or inspection activity, the heater must be switched off and cooled down completely. Do not use any abrasive materials or products to clean the heater, this includes solvents, citrus based cleaners or other harsh cleaning products.

When handling the heater, ensure that your hands are clean or that you use clean gloves as grease or dirt can mark the surface of the heater.

Do not use high pressure water to clean heaters, light water spray only.

IMPORTANT SAFETY INSTRUCTION

WARNING

These instructions should be carefully read before installation. The booklet must be kept and delivered to the new user. The Manufacturer reserves the right to vary the features of the product without prior notice. The technical data are indicative only.

1. THIS APPLIANCE IS HOT WHEN OPERATED AND CAN CAUSE SEVERE BURNS IF TOUCHED
2. Do not operate appliance before reading and understanding instructions. Failure to read instructions could cause fire or injury.
3. This heater is hot when in use. To avoid burns, do not let bare skin touch hot surfaces. Keep combustible materials such as furniture, pillows, bedding, paper, clothes etc and curtains at least 3 feet (0.9m) from the front of the heater and keep them away from the sides and rear (sides and rear restrictions apply to location dedicated heaters only).
4. Risk of burns. Please do not touch the appliance directly after use, allow to cool for at least 30 minutes. Please turn off the control and remove plug if you want it disconnect power of appliance.
5. Do not install damaged or incomplete components.
6. Extreme caution is necessary when any heater is used by or near children when the heater is left operating and unattended
7. Do not install damaged, incomplete or substitute components.
8. To prevent accidental ingestion keep small parts away from children and infants
9. There is small batteries in the remote. Please keep away from children
10. Do not install battery in wrong direction. Keep batteries away from fire, do not mix with other types of batteries
11. Ensure you have adequate safety measures to protect infants/children from touching hot surfaces.
12. It is imperative that the control components, circulating blower and ventilation channel in the appliance are kept clean. The appliance should be inspected before use and maintained by a qualified service person once a year.
13. Under no circumstances should this appliance be modified
14. Do not use this appliance if any part has been in contact with water. Please call a qualified service technician to inspect the appliance immediately and to replace the parts which has been in contact with water.
15. Do not operate the appliance when the glass element is removed, cracked or broken. Replacement of the glass element should be done by a qualified service technician.
16. Do not strike the glass element
17. Keep packaging material away from children, dispose of immediately.
18. Always unplug appliance when not in use
19. Do not operate heater if it malfunctions. Disconnect power at the service panel and have heater inspected by a licensed technician.
20. Never place appliance where it may fall into a bathtub or other water container.
21. Do not run cord under carpet. Do not cover cord with throw rugs, furniture's etc. Place cord away from cluttered area where it cannot be tripped over.
22. Connect to properly grounded outlets only
23. Do not insert or allow foreign objects to enter any ventilation or exhaust valve as this may cause an electric shock, fire or damage the appliance.
24. To prevent fire cases, do not block the air intake or exhaust valve in any way. Do not use appliance on soft surfaces such as carpet where exhaust valve may become blocked.

HEATSTRIP[®]



October 2025 Rev 8

CAUTION: For supply connections use 14 AWG or larger wires suitable for at least 75°C
THIS HEATER IS FOR MOUNTING ON A STANDARD OUTLET BOX
Do not install less than 2.4 meters from the floor.

CAUTION: METAL-SHEATH ELEMENT-TYPE RADIANT HEATER. CONNECT ONLY TO A CIRCUIT
PROTECTED BY SUITABLE GROUND-FAULT PROTECTION
UN CIRCUIT PROTÉGÉ PAR UN DISJONCTEUR APPROPRIÉ.

WARNING: RISK OF FIRE — KEEP COMBUSTIBLE MATERIAL AWAY FROM FRONT OF HEATER
AVERTISSEMENT : RISQUE D'INCENDIE — NE LAISSEZ PAS DE MATERIAU COMBUSTIBLE DEVANT LE
RADIATEUR.

SAVE THESE INSTRUCTIONS



Innovative, High Performance Electric Heating Technology

Features & Benefits

High Output radiant heat

The HEATSTRIP Max DC range of electric radiant heaters produces a high temperature radiant warmth that travels through the air directly to people and surfaces below – similar to the heat rays emitted by the Sun. Radiant heating is the only viable option for outdoor or tough indoor sites.

Dual Glass Element Design

Specially designed and engineered with a dual glass elements, which deliver high intensity instant heat. Ideal for coastal or hard to heat applications.

Maximum heat performance – multiple applications

The high temperature output of the HEATSTRIP Max DC is perfect for exposed outdoor sites, high ceilings and hard-to-heat indoor and outdoor applications.

The dual element design allows for a very compact unit, and maximum efficiency. Outdoor applications include al-fresco and dining/entertainment areas, patios, veranda's and balconies, to name a few. Indoor applications such as factories, warehouses, showrooms, workshops and workstation spot heating are ideal for the HEATSTRIP Max DC.

Suitable for permanent outdoor mounting, no protection needed.

For outdoor applications, the HEATSTRIP Max DC is suitable for both permanently exposed (eg. courtyards and patios) and undercover installations - does not need to be fully protected from the elements.

3 years residential and 3 years commercial full replacement warranty

It is fully supported by a 3 year residential warranty and 3 year commercial warranty replacement.

Corrosion protection

The HEATSTRIP Max-DC is suitable for use in most applications, including difficult corrosive environments such as coastal areas.

Multi-Purpose Mounting Options

The HEATSTRIP Max DC is supplied with flexible mounting options. The standard bracket will allow both ceiling and wall mounting, at various angles, as well as suspension by chains/wires. Extension rods are available as optional accessories.

2 models – hard-wired

2 models are available. The X-THX4000DC (4000W) & X-THX6000DC (6000W) requires hard-wiring supply.

The X-THX4000DC (4000W) requires hard-wiring to 20amp power supply

The X-THX6000DC (6000W) requires hard-wiring to 32Amp power supply.

HEATSTRIP®



Specifications - US & Canada

MODEL	POWER (WATTS)	VOLTS	CURRENT (AMPS)	DIMENSIONS (mm/in) (L x W x D)	WEIGHT (Kg / lb)	LEAD LENGTH (mm / in)	PLUG
X- THX4000DC	4000	240 V	16.6	1134mm x 170mm x 80mm 44 5/8" x 6 11/16" x 3 1/8"	5kg 11lb	1500mm 59 1/16"	NO
X- THX6000DC	6000	240 V	25	1274mm x 170mm x 80mm 50 3/16" x 6 11/16" x 3 1/8"	6kg 13lb	1500mm 59 1/16"	NO

MODEL

HEATER TYPE	High intensity electric radiant, infra-red overhead heater with dual glass element	
OUTPUT	Refer to model code chart above	
POWER	240 Volts Nominal at 50—60 Hertz, Single Phase (X-THX4000DC) 240 Volts Nominal at 50—60 Hertz, Single Phase (X- THX6000DC)	
CONNECTION	Gang Box	
APPROVALS		
MOUNTING HEIGHT	MINIMUM RECOMMENDED MAXIMUM	Minimum mounting height 2.4m / 7' 10½" Ideal mounting height 2.5m – 2.8m / 8' 2½" - 9' 2¼" Maximum mounting height 3m / 9' 10" (For higher ceiling heights, units can be lowered using optional bracket kits)
MOUNTING OPTIONS	Suitable for ceiling, wall, beam mounting. Also available for extension mount using rigid fixing poles and chain mount bracket.	
PROTECTION RATING	IPX5 Protection from water ingress from all directions	
MATERIALS OF CONSTRUCTION	Anodised alloy casing and end caps with a powder coated grille (Black)	

X- THX4000DC

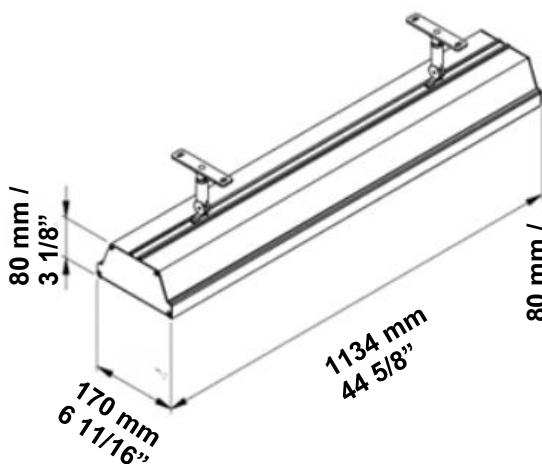

X- THX6000DC

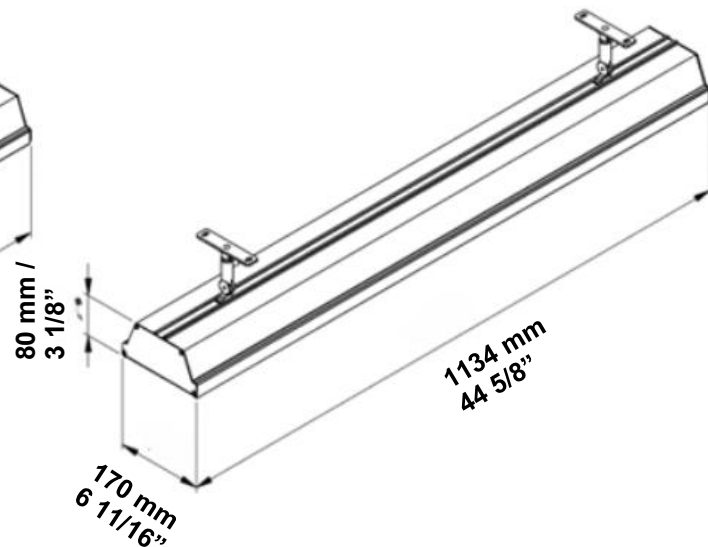



Spot heating principle

In most outdoor or difficult-to-heat indoor applications, there are 2 methods when looking at the size and quantity of heaters required.

Option 1 is to comfort heat the entire area based on the total dimensions of the space, regardless of whether the entire area is being fully occupied or not.

Option 2 is to spot heat the high use areas, such as over outdoor tables, BBQ's, lounges, assembly lines or indoor workstations.

Often it is more practical and efficient to spot heat these areas. Spot heating will help to reduce the initial capital cost, as well as the on-going running costs. Spot heating will allow the area to be "zoned", meaning heating only the areas that are being used, such as tables in a restaurant or outdoor alfresco area.

The top diagram shows how HEATSTRIP® Max DC is recommended to be used directly over a table, while the bottom diagram indicates how to spot heat a large area.

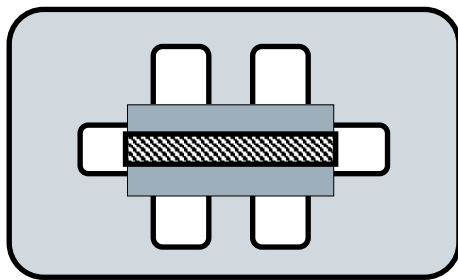

X-THX4000DC

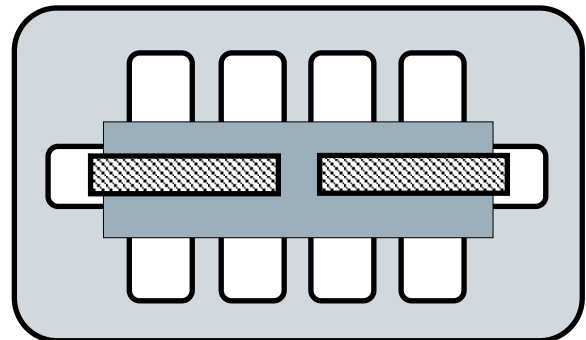

X-THX6000DC

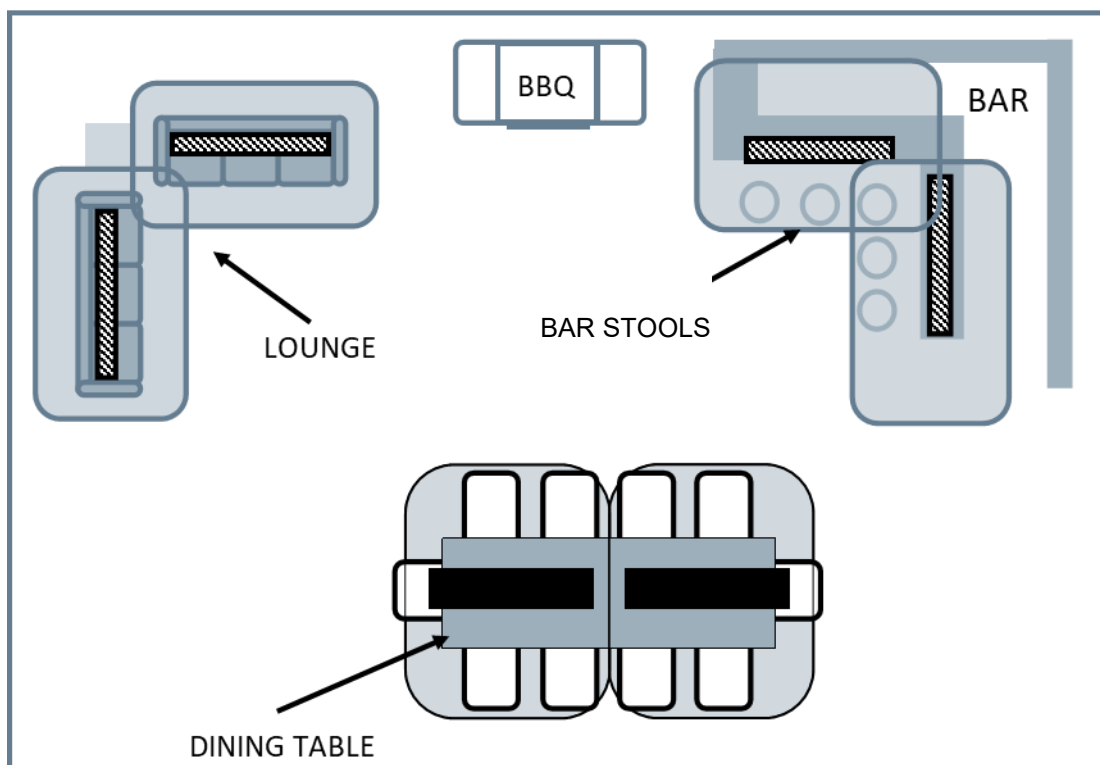



Radiant footprint

HEATSTRIP® Max DC electric heaters produce radiant heat, which heats objects rather than the air. Therefore, it is imperative that objects to be heated (ie. people), are within the direct radiant footprint of the heater.

The diagram below shows the radiant footprint of HEATSTRIP® Max DC, and is an approximate guide based on a fully enclosed, outdoor environment.

This diagram shows that the maximum heat output is found directly under the heater, and the temperature decreases as you move away from the heater.

It highlights the importance of maintaining recommended mounting heights, and positioning the heater directly above the area to be heated, if possible.

Also, the temperature (ie. surface temperature) is the same for both models, regardless of the wattage. However, as the size increases and the length of the unit increases, the radiant footprint will be larger.

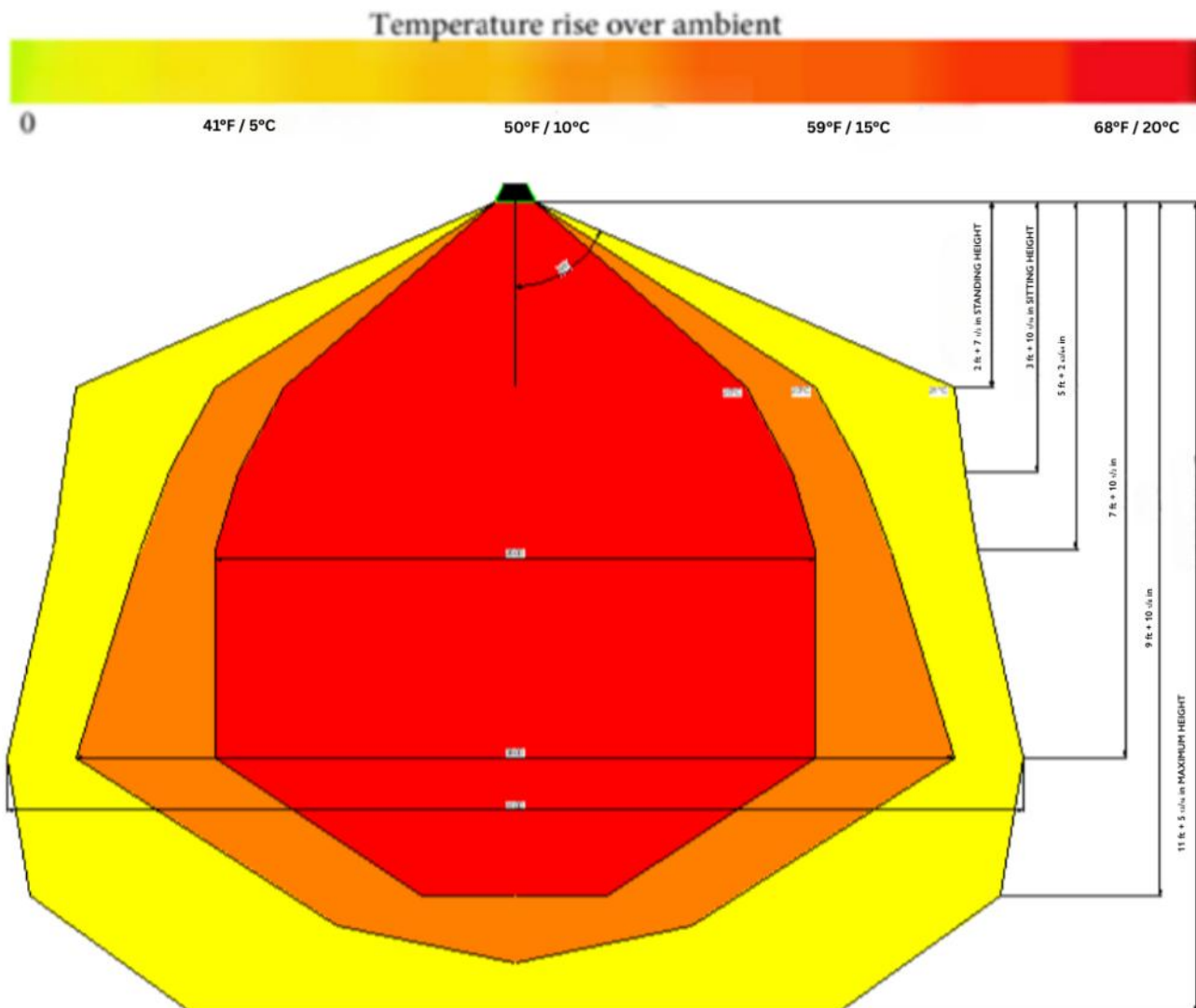

HEATSTRIP®



Selection guide

General recommendations for **HEATSTRIP® Max DC**:

Minimum mounting height 2.4m / 7' 10½"

Ideal mounting height 2.5m – 2.8m / 8' 2½" - 9' 2¼"

Maximum mounting height 3m / 9' 10"

Ideal mounting location: ceiling mounted, directly above area to be heated (Eg. above a table)

The below table outlines the coverage of each HEATSTRIP® Max DC model (in m²/ft²), based on 3 different scenarios. For example, in an outdoor area that is protected from prevailing winds by walls, café blinds etc, (eg outdoor enclosed), Model X-THX4000DC will cover (12m² / 129-3/16 ft² and Model X-THX6000DC will cover 16m² / 172-1/4ft²)

This data is based on direct overhead ceiling mounting. If the heaters are wall mounted, the radiant footprint will be reduced.

MODEL	OUTDOOR EXPOSED (ft ² / m ²)
X- THX4000DC	129 3/16 ft ² / 12m ²
X- THX6000DC	172 1/4ft ² / 16m ²

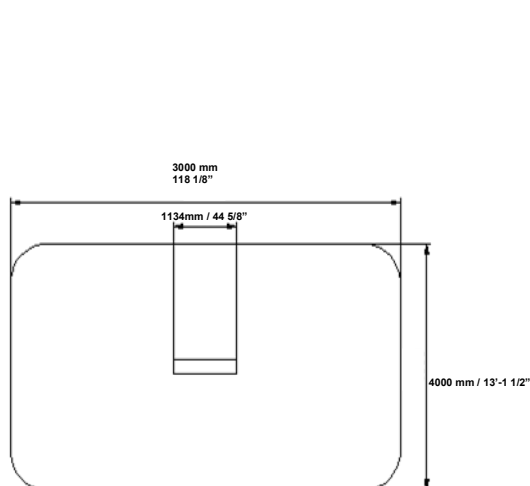

X-THX4000DC

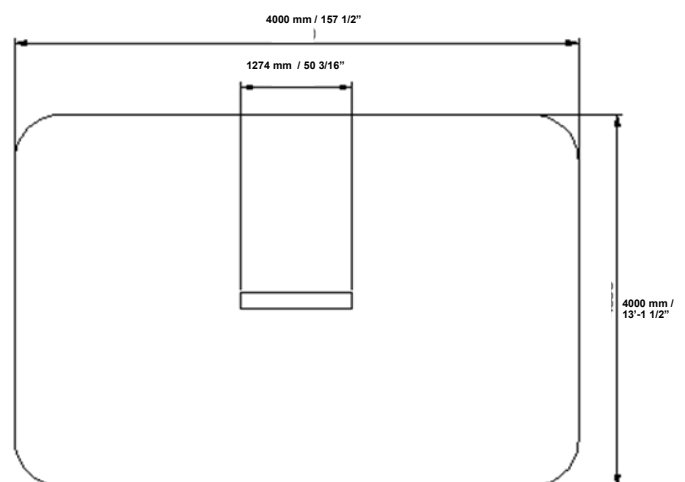

X-THX6000DC

HEATSTRIP®



Table layout

For the majority of outdoor applications, the most effective method is to spot heat a table or similar area. The below diagrams provides an easy selection guide for the approximate model and quantity of heaters required to heat common table settings.

Selections are based on HEATSTRIP® Max DC being mounted at 8'-10 5/16" / 2.7m from the floor and an undercover outdoor area.

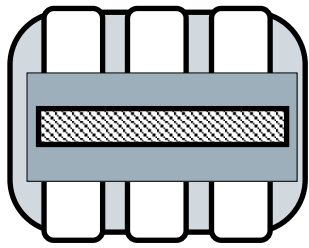

X-THX4000DC

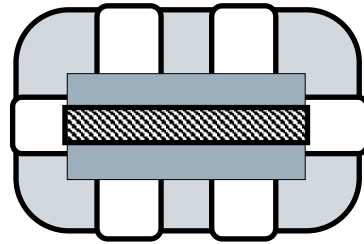

X-THX6000DC

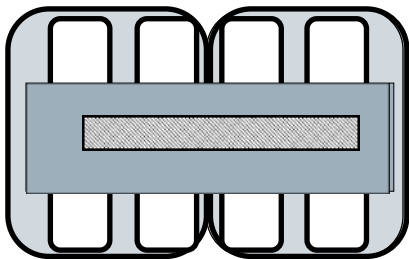

X-THX6000DC

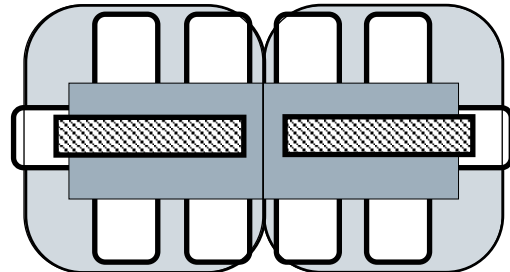

X-THX4000DC

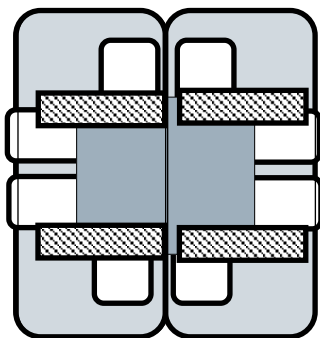

X-THX4000DC

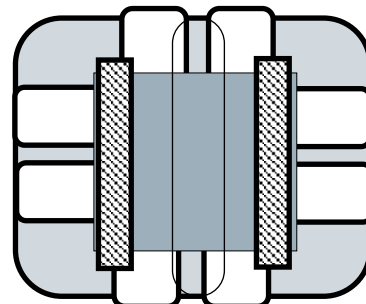

X-THX6000DC

HEATSTRIP®



Installation Requirements

The ideal mounting position for the HEATSTRIP® Max DC is on the ceiling, directly above the area to be heated. If this is not possible, HEATSTRIP® Max DC can be mounted on a wall and angled downwards. In this situation, ensure the mounting height is in the range of 2.5m to 2.8m (8'-2 7/16" — 9'-2 3/16") and the table is within 1 - 2m (3'-3 3/8" — 6'-6 3/4") of the wall.

For mounting heights more than 3.0m (9'-10 1/8") outdoors, we recommend the use of the optional accessories to reduce the height of the heater to 2.5m—2.8 m OR 8'-2 7/16" — 9'-2 3/16". This will increase the effectiveness of your HEATSTRIP®. Refer to the Mounting Accessory section for more information.

Electrical connections/GPO's should not be located at the back of the heater. They should be located outside the physical footprint of the units to minimize heat build-up behind the units.

The HEATSTRIP® Max DC is not suitable for mounting on an incline, along the length.

Minimum recommended clearance is required from combustible material – if the material is not combustible, the minimum clearance is reduced.

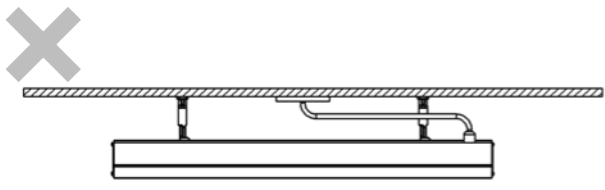
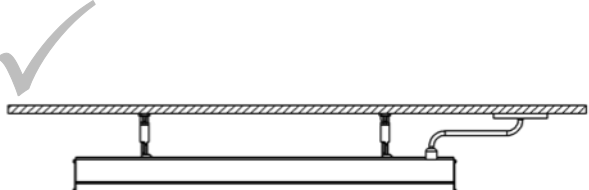
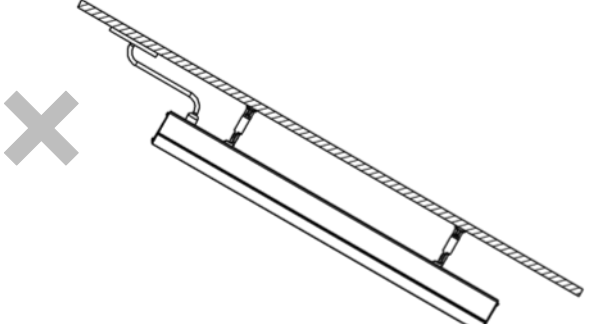
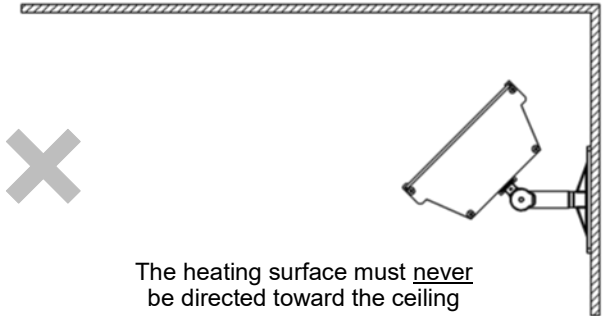
Incorrect Installation	Correct Installation
	
	
 <p data-bbox="312 2007 657 2065">The heating surface must <u>never</u> be directed toward the ceiling</p>	

HEATSTRIP[®]



Install-

Angled Wall Installation

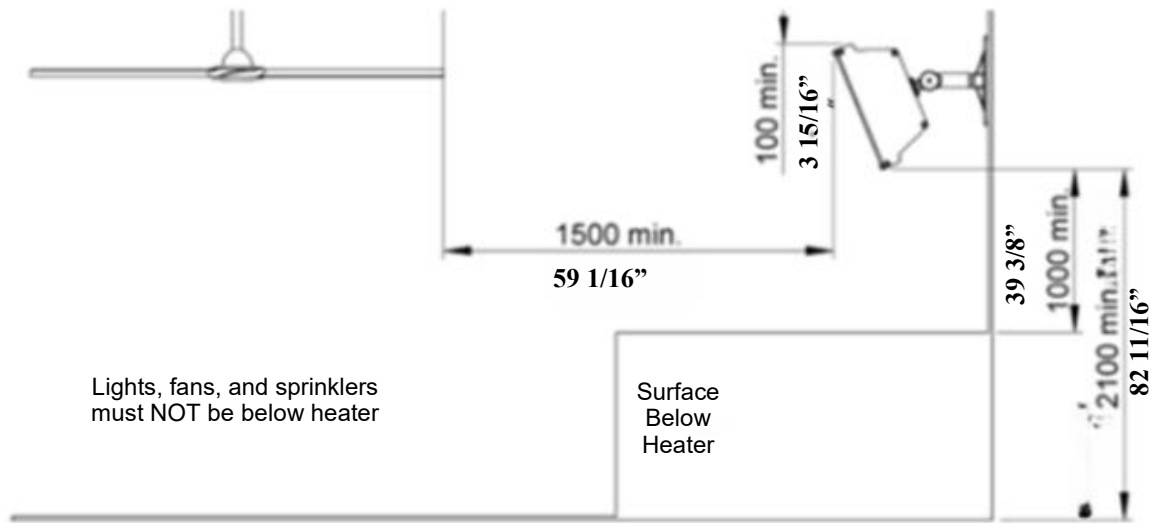

Ceiling Installation

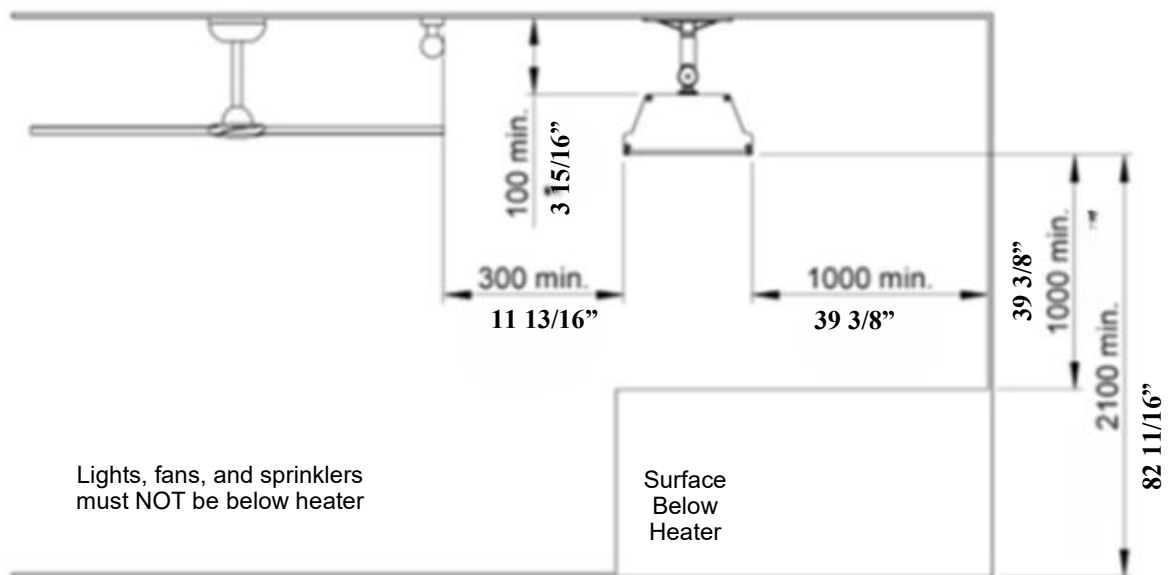

Angled Ceiling Installation

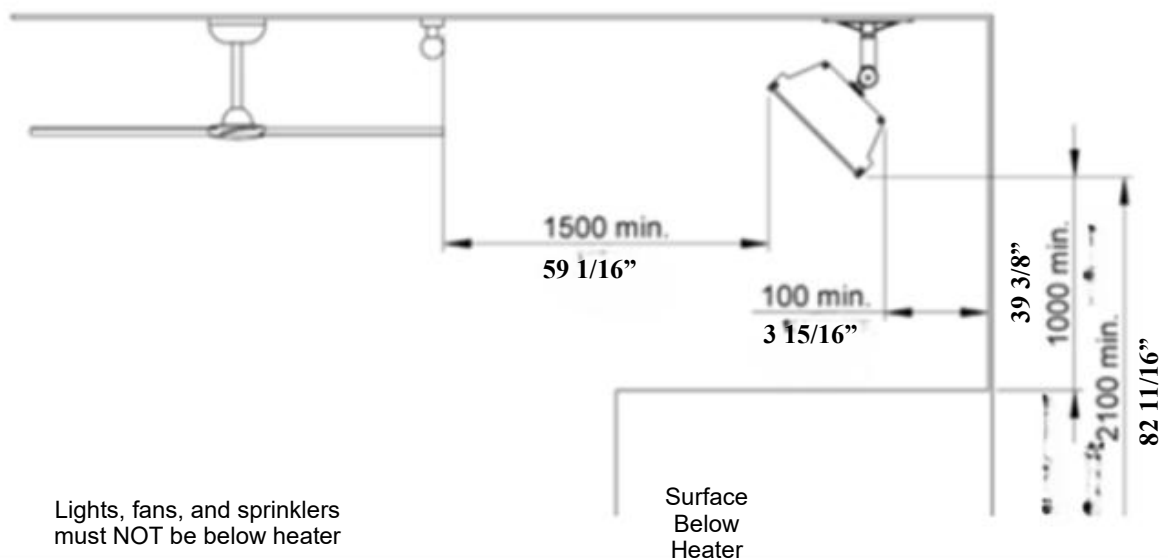

HEATSTRIP®



Mounting options

The installation of HEATSTRIP® Max DC is simple and easy with the standard mounting brackets supplied. For other more challenging locations there are a range of mounting options available - refer to below diagrams.

The HEATSTRIP® Max DC can be mounted directly to the ceiling, angled downwards on a wall, suspended on chains or poles, or attached to beams or poles. Refer to the following pages for more detailed information on each mounting option.

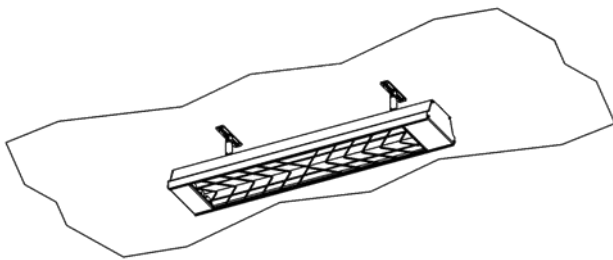
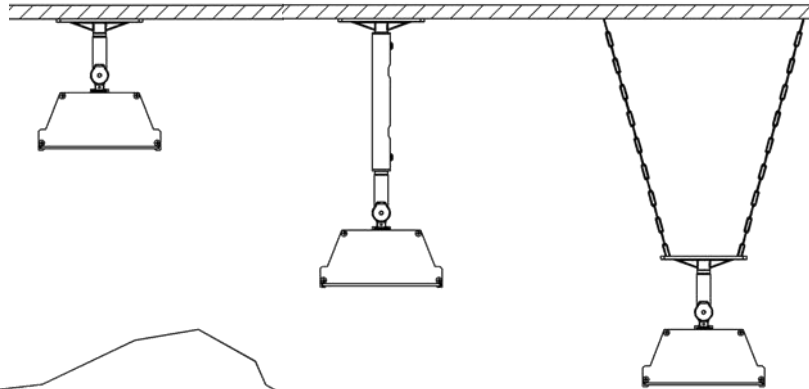

Standard Ceiling Bracket

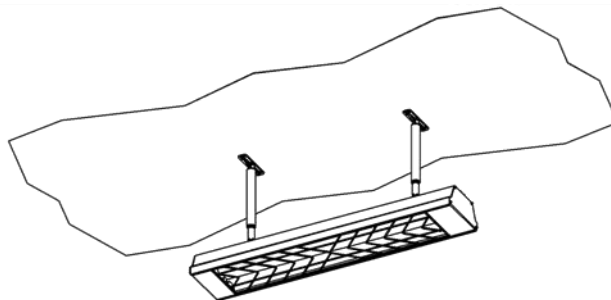

Extension Mounting Bracket

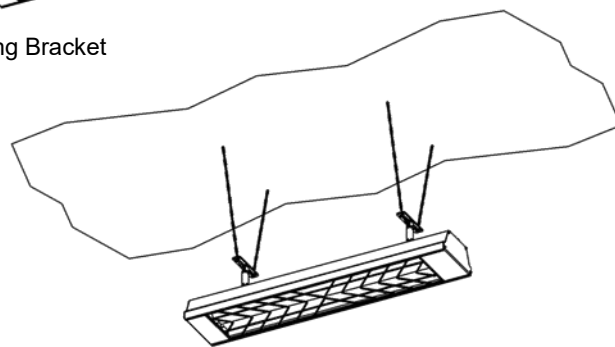

Chain / Wire Mounting



Standard mounting brackets

The HEATSTRIP® Max DC comes with a pair of standard mounting brackets. These adjustable brackets allow direct ceiling or wall mount, and come with pre-set angle options of parallel, 22.5° and 45°.

The flexible standard mounting bracket can be turned 90 degrees to mount onto a beam, it can also be used to suspend with chains.

The brackets need to be mounted onto a secure frame or wall with a minimum distance between the two brackets. The minimum distance ("B") for each model is listed on the next page.

When completing the installation, ensure all screws are tight and unit is secure.

Note: When suspension mounting, chains are not included.

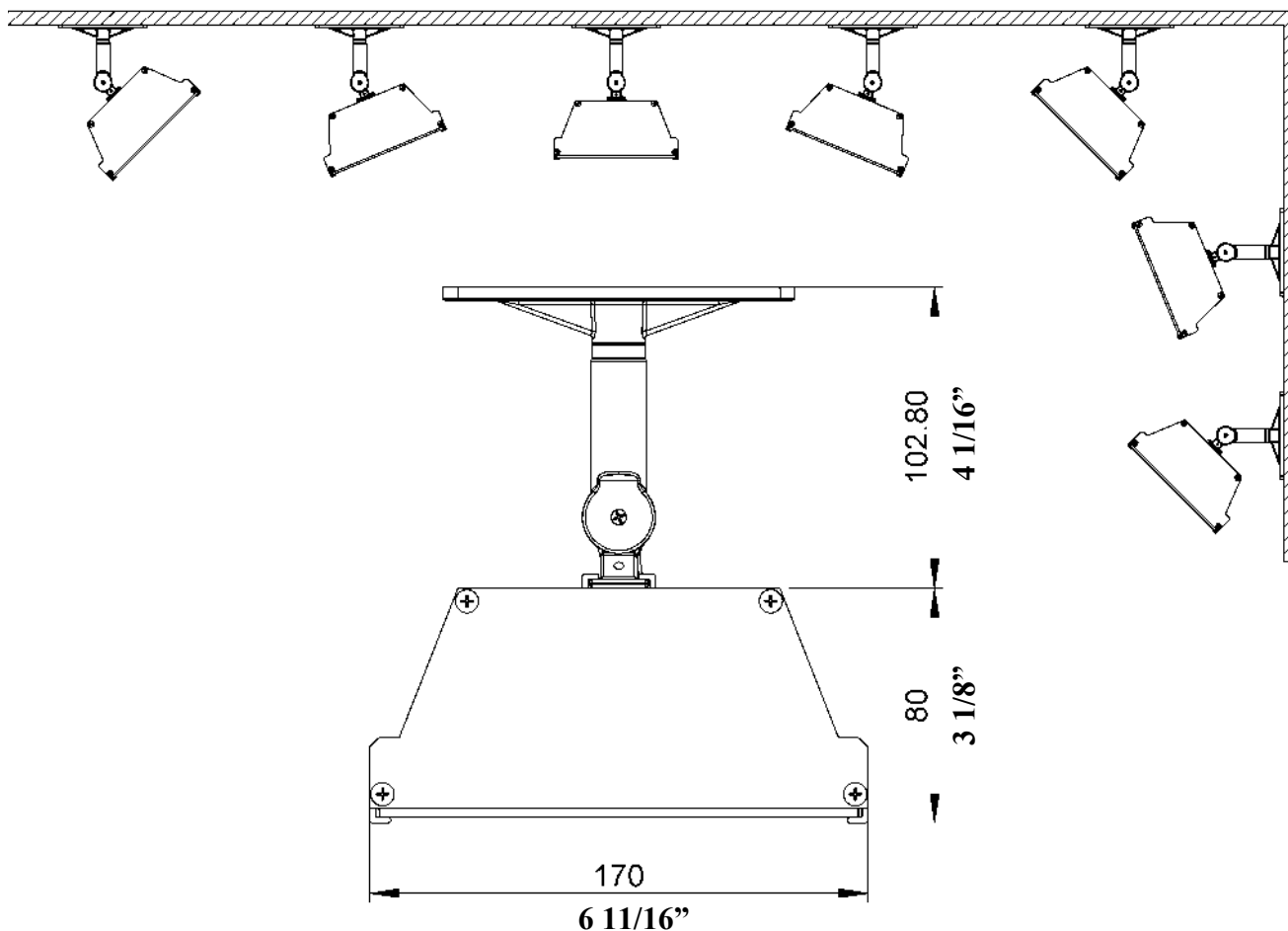

Standard Mounting Bracket

PART No	PACKAGED DIMENSIONS (mm/in)	WEIGHT (kg/lb)	MATERIALS
ZBRAK-132B	125mm x 100mm x 40mm (4 5/16" x 3 5/16" x 1 9/16")	0.2kg 0.44lb	ALLOY

HEATSTRIP[®]



MOUNTING

Fix the two mounting brackets to the ceiling or wall in the desired location (refer minimum bracket centre chart). Make sure the method of fixing (bolts or screws) will be more than strong enough to support the weight of the heater, allowing for strong winds and other conditions.

- Slide the 2 locking brackets into the groove on the back of the heater. Make sure the pins on the locking bracket are facing the matching holes in the top mounting bracket.
- Lift heater into position and secure the 2 locking brackets to the mounting brackets using the screws provided. Make sure the 2 pins on the locking bracket engage with the matching holes in the mounting bracket. The pins will allow for both horizontal or angle mounting as required
- Tighten all screws and tighten the round nut at the top of the bracket, so it locks onto the top part of the mounting bracket.

NOTE: the standard bracket allows for normal or angle mounting of the heater and is suitable for ceiling or wall mounting.

MODEL	"B" MINIMUM DISTANCE (mm/in)
X-THX4000DC	400mm (15 3/4")
X-THX6000DC	600mm (23 5/8")

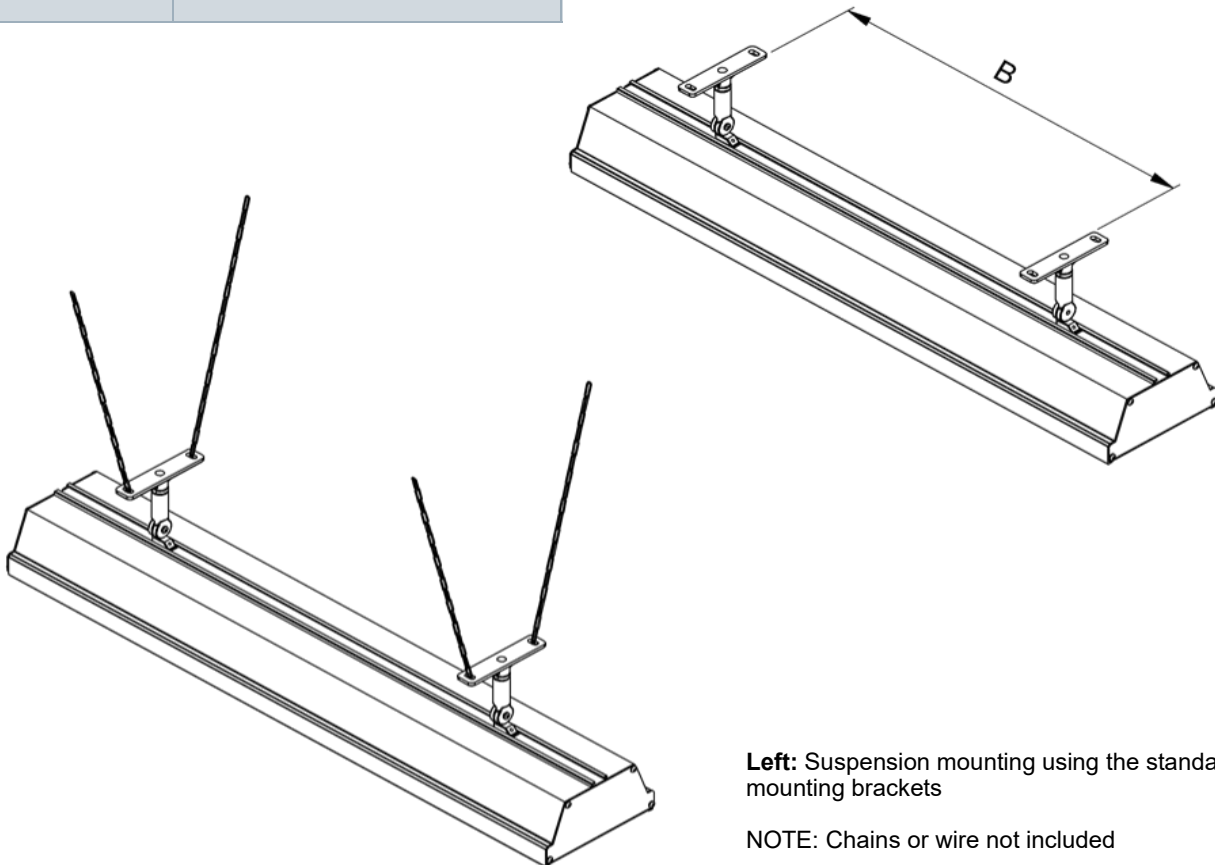

Left: Suspension mounting using the standard mounting brackets

NOTE: Chains or wire not included

HEATSTRIP®



Extension Mount Bracket

The Extension Mount bracket allows HEATSTRIP® Max DC units to be lowered from high ceilings, using rigid connections. The brackets are designed to be used with 20mm x 1mm (13/16" x 1/16") round tube (SHS), and supplied as a complete kit that attaches to standard mounting brackets supplied with the heater. The standard length options as part of the kit are 150mm (5-7/8"), 300mm (11-13/16"), 600mm (23-5/8"), 900mm (35-7/16") and 1200mm (47-1/4").

Note: Standard brackets provided with the HEATSTRIP Max DC heaters is required when using the extension mounting poles. *screws to ceiling are not included

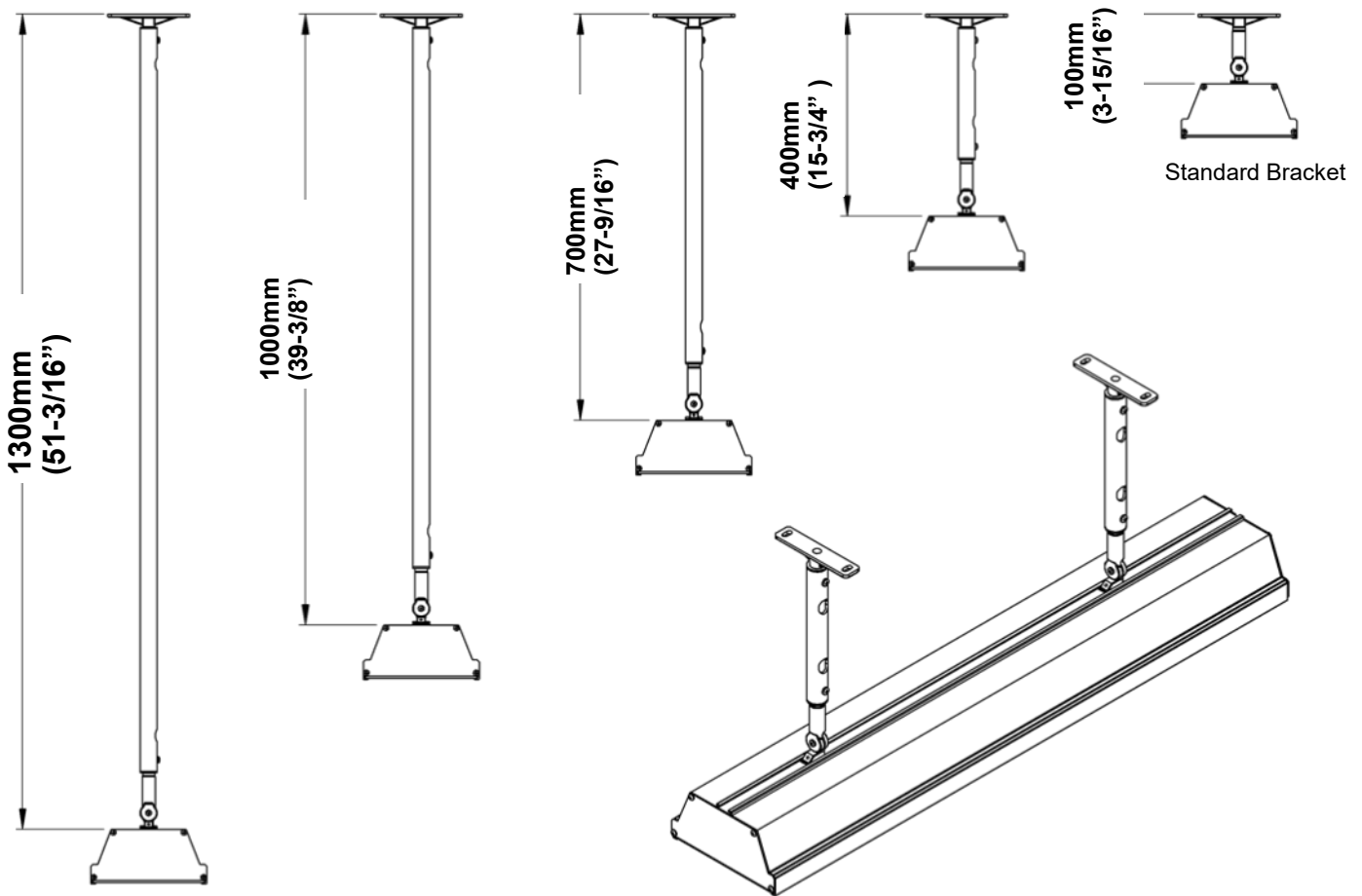

PART No	PACKAGED DIMENSIONS (mm/in)	WEIGHT (kg/lb)	MATERIALS	NOTES
THYAC-047	300mm x 150mm x 50mm (11 13/16" x 5 7/8" x 1 15/16")	0.21kg 0.46 lb	Alloy	Kit includes 2 x 300mm (11 13/16") extension poles, Black
THYAC-048	600mm x 150mm x 50mm (23 5/8" x 5 7/8" x 1 15/16")	0.38kg 0.83 lb	Alloy	Kit includes 2 x 600mm (23 5/8") extension poles, Black
THYAC-049	900mm x 150mm x 50mm (35 7/16" x 5 7/8" x 1 15/16")	0.55kg 1.21 lb	Alloy	Kit includes 2 x 900mm (35 7/16") extension poles, Black
THYAC-050	1200mm x 150mm x 50mm (47 1/4" x 5 7/8" x 1 15/16")	0.71kg 1.56 lb	Alloy	Kit includes 2 x 1200mm (47 1/4") extension poles, Black



Wiring Schematic

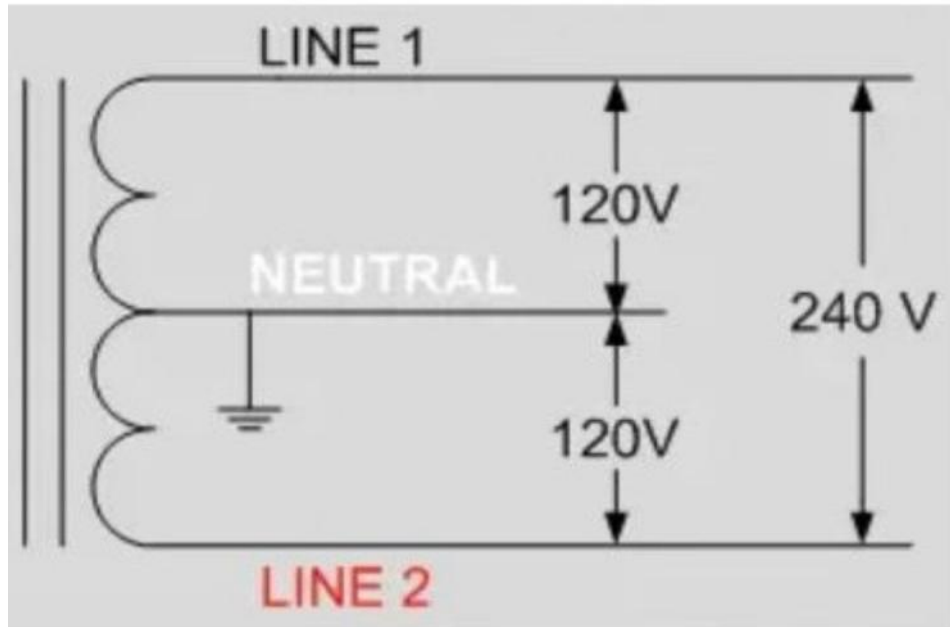

The entry line in North America is a single-phase three wire system, with 120V between L and N and 240V between L1 and L2.

Run another circuit with 2 live wires (to use 240VAC) + Ground wire.

- Live 1 connect to L
- Live 2 connect to N (mark label L2 on N terminal). Don't connect Neutral wire to N terminal,
- Ground wire connects to G

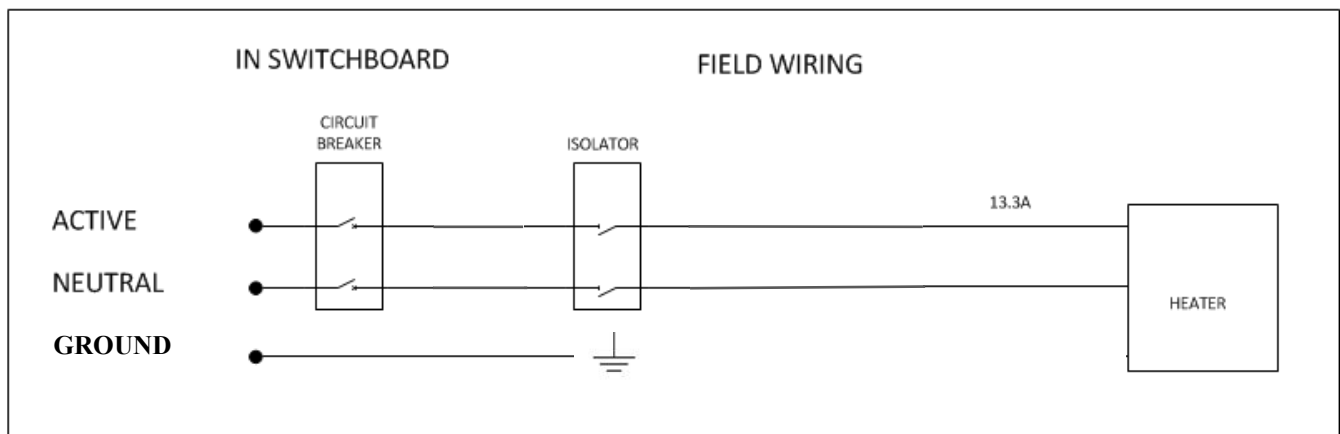



Warranty Terms & Conditions

The below Warranty Terms and Conditions apply for **International Customers**. For international warranty please refer to international warranty terms and conditions.

Thermofilm warrants to the original owner that HEATSTRIP[®] Max DC products will be free from defects in materials and workmanship for a period of 3 years for commercial & residential applications, from the date of purchase in accordance with the following warranty terms and conditions.

Provision of this warranty is subject to:

- The HEATSTRIP[®] product must be installed in accordance with the Installation Instructions and relevant electrical standards and codes.
- The HEATSTRIP[®] product must be maintained and cleaned according to instructions detailed in the Installation Manual.
- There is no warranty expressed or implied with regard to capacity requirements. The selection of the unit or units depends entirely upon the system design and capacities as determined by the purchaser.
- The customer has not repaired, opened or altered the product in any unauthorised manner.
- This warranty excludes damage to the product or components arising from circumstances outside the control of Thermofilm, including, but not limited to, where the product is not used for intended purpose; where the product has been rectified in any way; incorrect installation; incorrect power supply; damaged caused during delivery; misapplication, misuse, abuse, vandalism, lack of maintenance or accident.
- Thermofilm's obligations under this warranty are limited to repair or replacement at Thermofilm's factory of any components of the product which Thermofilm identifies to its satisfaction to be defective.
- Transportation charges involved in return of the product to the Thermofilm factory (or any other location authorised in writing by Thermofilm) is the sole responsibility of the customer.
- All products are inspected and tested before despatch and are at the risk of the purchaser after the shipment from the Thermofilm factory, if not delivered by Thermofilm to destination.
- Discolouration of the surface may occur after a period of time, this does not constitute a warrantable event.
- Twisting and bending of the heaters may occur, this does not constitute a warrantable event.
- No products or components will be supplied in advance of an examination of the faulty product or components by Thermofilm or an authorized representative of Thermofilm.
- Thermofilm does not participate in any site related costs or labour expenses incidental to replacement of parts, repairing, removing, installing, servicing, transportation or handling of parts to complete products, and assumes no liability on parts repaired or replaced without written authorisation. Thermofilm shall not be liable for any default or delay in performance of its warranty obligations caused by any circumstances beyond its control, including, but not limited to, judicial or government restrictions, strikes, fires, floods, abnormal weather conditions, delayed supply of components.

Should products be determined as damaged on arrival, immediately notify the transport company of the condition and have them noted on the freight documents. If damage is discovered after unpacking, demand immediate inspection by the transportation company and insist that a record of the damage is made on the freight documentation.

The customer warrants using the product in accordance with:

- Any instructions provided to it by Thermofilm from time to time.
- All government and local regulations, including but not limited to all relevant electrical, environmental laws and regulations governing the installation, storage, use, handling and maintenance of the goods.
- All necessary and appropriate precautions and safety measures relating to the installation, storage, use, handling and maintenance of goods.

Our goods come with guarantees that cannot be excluded under the Australian Consumer Law. You are entitled to a replacement or refund for a major failure and for compensation for any other reasonably foreseeable loss or damage. You are also entitled to have the goods repaired or replaced if the goods fail to be of acceptable quality and the failure does not amount to a major failure.

All warranty requests for repairs or replacements must be accompanied by a complete "Warranty Claim Form" available from Thermofilm, together with proof of purchase (and where possible, photos of the installation) and the heater returned to the place of purchase.

In the event of a warranty claim, the goods need to be returned to the distributor/retailer for repair/replacement. Contact

Website: Heatstrip.com

Address: 1600 Riverfork Drive East, Huntington, IN 46750

Phone: 720-470-7930

Email: brand-architect@heatstrip.com